

## Smartphone Processor Architecture

Hemlata Kohad<sup>1\*</sup>, Asha Ambhaikar<sup>2</sup>

<sup>1</sup>Dept. of Electronics & Communication, Rajiv Gandhi college of Engineering, Chandrapur (Maharashtra), India

<sup>2</sup>Kalinga University, Raipur (Chhattisgarh), India

Corresponding Author: [hemlata.pangantiwar@gmail.com](mailto:hemlata.pangantiwar@gmail.com),

Available online at: [www.ijcseonline.org](http://www.ijcseonline.org)

**Abstract**— Smartphone plays a crucial role in our daily life. Day by day there are advancements in technology which import changes in architecture of mobile phones. Low power, communication and performance largely affects the processor architecture of mobile phones. Processor architecture is now become complex to support the digital telephony. Mobile phones Processor design growing rapidly with respect to last generations. The objective of this paper is to overview the architecture of processor in Smart phones.

**Keywords**— Processor architecture, ARM Processors, SoC

### I. INTRODUCTION

The design constraint of smart phone processor is different from PC and laptop. The performance should be balanced with the power consumption [1]. For designing smart phone if we are using Intel core i7, battery will drain out in few minutes and if it is 8-bit microprocessor we are not able to view you tube videos. The hardware of smart phone is having SoC, SDRAM/DDR, ARM processors etc. Every smart phone consist of number of ARM microprocessors and multi core GPUs. Nvidia Tegra Qualcomm Snapdragon, S4, and the Exynos are the high performance chips can be used for the design of smart phones. High resolution displays, enhanced communication displays and data traffic is also increasing therefore the smart phone processing load is increasing as a result power consumption is also increases which creates to increase CPU performance. [2](Trends in Hardware Architecture for Mobile Devices). Every smart phone uses SoC architecture with three primary components.

- The instructions from the middleware and operating systems are executed by the Application Processor.
- Data from various peripheral devices, audio signal, video signal and baseband radio transmission performed by baseband processor with its own operating system components.
- Audio signals, video/image signals, position from GPS is collected by the radio Operating system components and the device drivers write the data to be transmitted in memory.

Operating System programs and user applications are executed by the application processor. Graphic intensive applications are executed by the GPU. Typically large volatile memory SDRAM around 1-2 GB and large non-volatile memory around 10 GB is used in modern smart

phones. Linux Operating system is optimized for Smart phone.

### II. POPULAR MOBILE OPERATING SYSTEMS

Operating System is the most important software in smartphone. The hardware and software resources are managed by the operating systems.

**Android or Droid technology:** It is recently used in the smart phones developed by Google, as it is open source technology the people can develop the program codes and different applications for the operating systems. The users of the Smartphone with Android Operating system allows the user to decide which application to be downloaded, multiple applications can be run by the Android operating system, it allows the multitasking moreover any hardware manufacturer is free to manufacture its own Android phone by using this Operation System. Thousands of App's are stored in Android App's.

**Apple iphone os / ios:** It is the innovating and the world's most advance mobile Operating System. It supports number of Apple devices like iphone, ipad, ipad2, and ipad touch. Apples own manufacturing devices only use the ios mobile operating systems, company does not license the OS for third party hardware.

**Bada(Samsung):** It is the Samsung mobile Operating System. It was launched in 2010. The first Samsung mobile which uses this operating system is Samsung Wave. Bada provide 3D graphics, multipoint-touch and Application downloads and installation.

**BlackBerry Operating System:** It is developed by Research In Motion used in companies handheld devices. The Blackberry

platform is popular with the corporate users as it provides synchronization with the Microsoft Exchange, Lotus Domino, Novell Group wise email and other business software when used with the Blackberry Enterprise server.

**MeeGo:** It is the joint open source Operating System results from merging of two products based on two open source technologies Maemo(Nokia) and Moblin (Intel). Smart phones, netbooks, tablets, in-vehicle information systems and various device using Intel Atom and ARMv7 architectures are designed using MeeGo operating System.

**Palm OS (Garnet OS):** This OS was originally released in 1996 on the pilot 1000 handheld .Newer versions of Palm OS support the expansion ports, new processors, external memory cards, improved security and support the ARM processors and smartphones. Palm OS5 provide support to broad range of screen resolutions,wireless connections and enhanced multimedia capabilities .

**Symbian OS (NOKIA):** This Operating System provides high level of integration with communication and personal information management. It combines the middleware with the wireless communication through the integrated mailbox and the integration of Java and PIM functionality. Symbian platform available as alternative as open and direct model to work with some OEMS and the small community of platform development collaborators. Nokia does not allow Symbian as an open source development project.

**WebOS(Palm/HP):** This Operating System was developed by Palm as the successor of PalmOS operating System. This Operating System runs on the Linux Kernel.Several Smartphones and HP Touch pads uses WebOS operating System. Security features are then improved by HP and then they released a new version 3.x.HP and were installed on all HP desktop and notebook computers in 2012.

**WindowsMobile(Windows Phone):** This Operating Systems are used in Smartphones and mobile devices . Mobile OS is windows CE5.2 kernel based Operating System. Windows phone 7 is a new smartphone platform announced in 2010 by Microsoft.

### III. TECHNOLOGICAL TRENDS IN MOBILE PHONES

A company loses clients if it offers mobile without optimized solution. App market grows because of competitiveness. According to analyst consumers downloaded 200 billion apps in 2017 and it will reach more than 350 billion by 2021.

Number of mobile app downloaded worldwide in 2016, 2017 and 2021(in billions) are shown in figure 1.

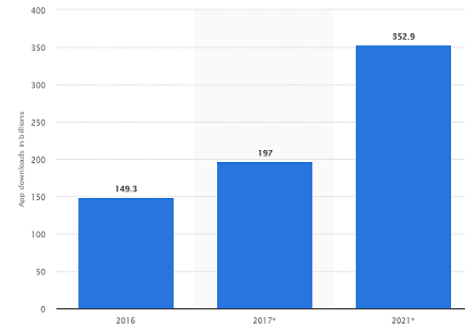
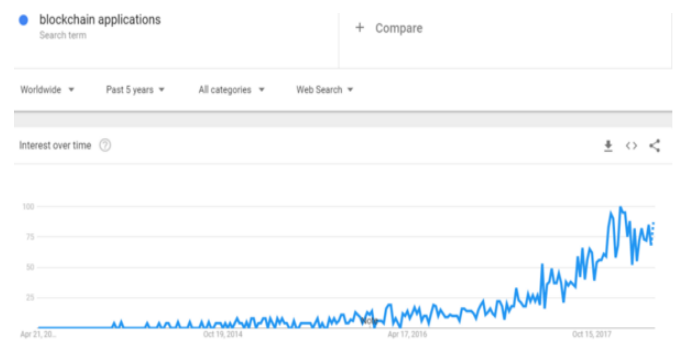

Fig.1 mobile app downloaded world wide

Security approach to protect personal data and earn customer loyalty. According to Google there is increasing development in blockchain applications.



The Block chain Technology provides security to customer over mobile platform.

#### A. IoT Apps :

It bridges the gap between connected device and people. As per the statista in 2018 the number of IoT connected devices will be more than 23 billion worldwide and by 2025 it will be around 75 billion.

IoT connected devices from 2015 to 2025 in billions the adoptions of different gadgets leads to the growth in mobile industry. The hottest Technological trends in 2018 that will shape the near future are Blockchain App.

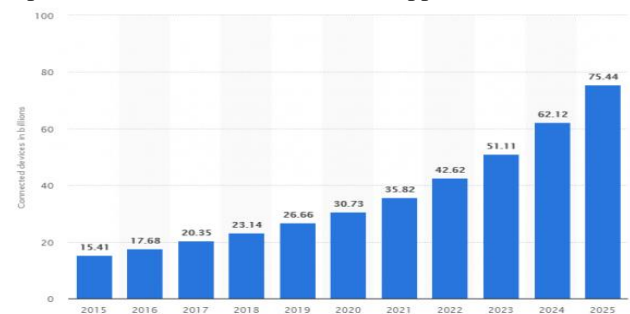

Mobile phone is the bridge between the intelligent systems and the people. IoT allows you to monitor the reading of

devices and sensors. It builds the chart and reports by analyzing the data. It also manages the different operations of device.

#### B. Cloud Apps:

It solves the big sized problems. Developers are interested in cloud developing apps and creating the mobile cloud era. Mobile internal memory require a lot of storage as it integrates the artificial intelligence, machine learning, IoT, etc. Cloud computing solves this problem easily. Cloud computing provide the necessary storage space for downloading the app and it will not affect the internal storage space of mobile. It provides secure functioning across multiple devices. It saves money in hosting. It is having much more storage and loading capacity. Different mobile apps are now cloud based.

#### C. Augmented Reality:

Recently the AR techniques are used for gaming apps and marketing to impress the customers. Harry Potter game is preliminary expected in 2018 based on new AR. This year mobile technology trends shows more practical applications using AR like Object Measurement, Navigation, interior design, user manuals etc.

#### D. Artificial Intelligence:

Since 2017 mobile industry focused on artificial intelligence. Specialists predict that the more apps will predict the voice commands and going to become more intelligent and able to make decisions.

#### E. 5G connectivity:

The advanced technology like IoT, AR, AI can be possible to implement due to enhancement in wireless connectivity. In December 2017 the world's regulator of cellular communications standards 3GPP approved the first specifications of 5G technology. The 5G standards provide 100X faster connectivity than 4G which improves advanced technologies in mobile.

#### F. Mobile payments:

Now days online shopping is the trends in mobile technology. Customers prefer online shopping compared to traditional alternative .customers make online payments via internet banking and credit cards. This now changed to Google wallet, Apple pay and other mobile payment apps and leads to the expansion of smart phones and tablets in mobile commerce. As these are the comfortable options for the customers, it makes all transactions easier and faster. Experts forecast that the world wide mobile payment will be around 1 trillion U.S. dollars in 2019.

Total Revenue of Global mobile payment from 2015 to 2019 (in billion U.S. Dollars)

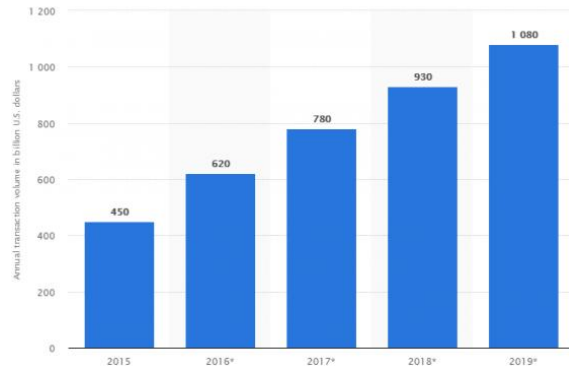

#### G. Security:

In 2018 the developers pay attention to provide the security to mobile phones as it manage the confidential data. They use the blockchain technology to provide the security to mobile phones.

### IV. TOP MOBILE DEVELOPMENT PROGRAMMING LANGUAGES IN 2018

#### A. Kotlin:

Since 2010 this language is in existence as the alternative to Java .Google introduced as official language in 2017 for the development of Android. Because of its simple syntax and purely mobile oriented which makes development faster than in java. Thus many apps are developed in Kotlin .

#### B. Java:

It is the main language for the development of Android native apps. This language is popular because of its reusability.

#### C. Swift:

Native ios applications are developed using swift which is developed by Apple. It is having open source code ,it also benefited for the speed and easy for learning and maintainance.

#### D. Objective –C

Some developers still use this language .it is benefited for mobile development and macOS.

#### E. HTML5 + JavaScript

This language effectively used for the mobile app creation its main objective is the cross-platform compatability,adaptivness to different screen sizes and high speed.

### V. PROCESSOR IN MODERN SMART PHONE

While designing todays smart phone SoC architecture is used.

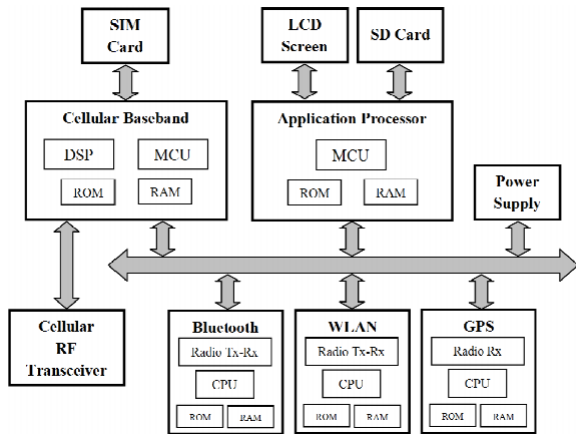

Fig 2 peripheral devices connected with smartphone for user interface

A modern smartphone is having multiple application processors (2, 4, or 8).

The Samsung Galaxy S4i9500 is having following configurations:

- 1.9 GHz quad-core ARM Krait+Qualcomm;s Adreno GPU
  - 1.6 GHz quad-core ARM Cortex A-15 +1.2 GHz quad-core ARM Cortex –A7 +Imagination’s VR GPU
- The Apple iPhone5 is having following configurations:
- 1.3 GHz dual –core Swift+Power VR GPU
- Nokia Lumia 920T is having following configurations:
- 1.7GHz dual-core Qualcomm Krait +Ardeno GPU
- Lenovo K900 is having following configurations:
- 2 GHz dual-core Intel Atom Z2580 + PowerVR GPU
- Samsung Nexus 10 is having following configurations:
- 1.7 GHz dual-core ARM Cortex-A15 + ARM Mali-T604 GPU
- Asus Nexus 7 is having following configurations:
- Nvidia Tegra 3 platform + 1.2 GHz quad-core ARM Cortex-A9 + ultra-low power Nvidia GeForce GPU

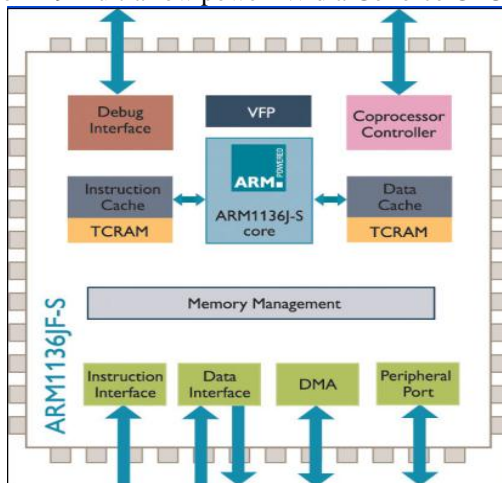

Fig3 Typical Architecture of ARM Processor used in a smart phone

Application Processor (APU) is the heart of the smartphone. It identify the chips in smartphone that run the operating system and applications software . Nowadays every smart phone integrates multiple ARM processors along with the multiple graphic Processing unit(GPU), large on chip cache memory , memory controllers for the controlling of DRAM ,USB host, audio /video decoders and encoders and analog functioning circuits .Texas Instruments Open Multi-media Applications software(OMAP) which is used in Kindle Fire Tablet and Google glass. Todays smartphone APUs combine the SoC and SiP technology.

System on Chip consist of microprocessors that can run the software and communication sub system to connect,control ,direct and interface between different functional units. The Soc typically have more than one processor It may be microprocessor, microcontroller, Digital signal processor(DSP), Application Specific Instruction set Processor(ASIP) . SoC processors are single-core, multi-core or many core uses RISC instruction set architectures.RISC architecture is more advantageous than the CISC architecture as it require less digital logic and hence less power consumption.

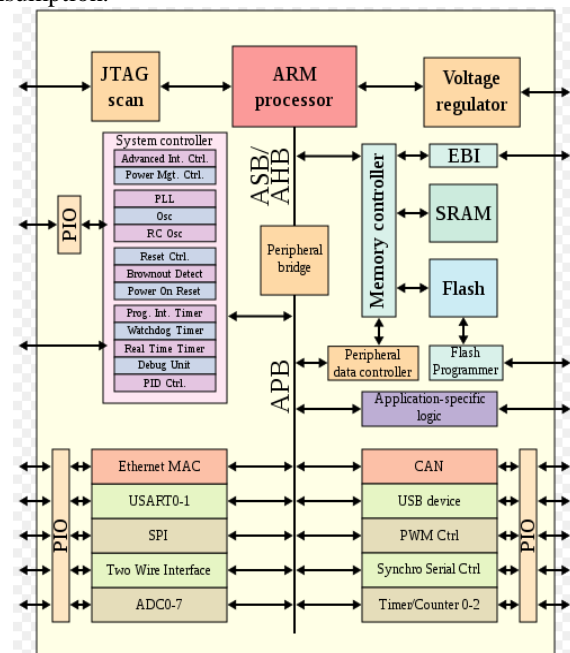

Fig 4 Microcontroller based SoC architecture

Memory technology used for SoC are ROM, RAM, EEPROM, and flash memory.RAM are divided into static RAM (SRAM) and dynamic RAM (DRAM).SRAM is usually used for the implementation of processor registers and core’s L1 caches while DRAM used for the implementation of lower level of cache including main memory . SoC ‘s external interfaces are used for the communication and is based on different company standards



as USB, FireWire ,Ethernet, USART, SPI, HDMI, I<sup>2</sup>C . With reference to the applications these interfaces will change. There are different categories of cortex processors as follow:

A. ARM Cortex Processor:

- Cortex-A Processors (ARM Application Processors)
  - Cortex-R Processors (ARM embedded Real-time Processors)
  - Cortex-M Processors (ARM Embedded Processors)
  - Secure core Processors (ARM secure Processors)
- The following figure shows an architecture of Cortex-A8.

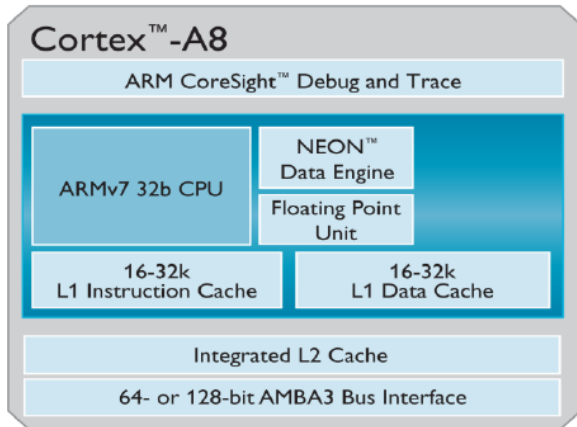

Fig5. Cortex A8 Architecture

This architecture uses NEON and SIMD media , audio, video and 3D graphics are provided by the signal processing technology for mobile applications. The clock frequency is around 3 GHZ. The computing capability get now increased with the use of 64-bit ARM processors. Cortex-A50 processor series consist of ARMv8 architecture having Cortex-A53 and cotexA57 architecture. Cortex A53 is providing better power efficiency .

B. Qualcomm Snapdragon Processor:

This year Snapdragon is likely to be heart of the Android phone in US. Qualcomm’s 845 is the upgraded version of snapdragon 835 which was used in 2017. It supports AI and neural network which is having multi-core Neural Processing Engine (NPE) which uses a new version of Hexagon DSP , CPU and GPU for the interfacing. This chip consist of Hexagon685 DSP with Kryo385 CPU which increases the performance by 25 to 30 % compared to that of the Four ARM Cortex-A75 which runs at 2.85 GHZ , with 2MB L3 cache and Adreno630 GPU which reduce power by 30 % with 2.5 times faster display.

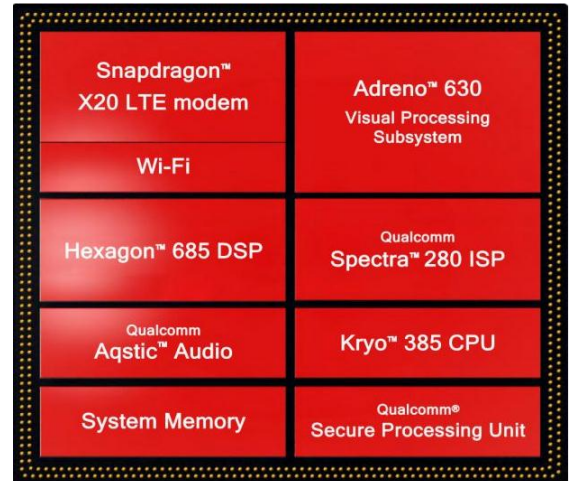

Fig6 Block diagram of Qualcomm Snapdragon Processor845

As it uses Adreno630 increases the efficiency it saves tons of calculations and improves the frame rates.

C. Nvidia Tegra Processors:

Nvidia developed a System on Chip (SoC) for development of mobile devices like smart phones personal digital assistants and mobile internet devices. The Tegra processor integrates the ARM architecture central processing unit , Graphic processing Unit.

The Tegra2 is the second generation Tegra SoC having dual core ARM Cortex –A9 CPU and an ultra low power GPU , 32 bit memory controller with LPDDR2-600 or DDR-667 memory , 32KB/32KBL1 cache per core and shared 1 MB L2 cache. Tegra 2 Cortex A9 implementation which does not having ARM’s SIMD extension, NEON .It supports 3D displays with higher clocked CPU and GPU. And for manufacturing Tegra2 it uses 40nm semiconductor Technology.

Table1. CPU and GPU performance

Model number	CPU		GPU			Memory			Adoption Availability			
	Processor	Cores	Frequency	Micro-architecture	Core configuration <sup>1</sup>	Frequency	Type	Amount		Bus width	Bandwidth	
AP20H (Ventana/Inkown)	Cortex-A9	2	1.0 GHz	VLIW-based VEC4 units <sup>200</sup>	4:4:??	300 MHz	LPDDR2	?	32 bit single-channel	2.4 GB/s	Q1 2010	
T20 (Harmony/Ventana)						333 MHz	DDR2					2.7 GB/s
AP25						400 MHz						
T25												

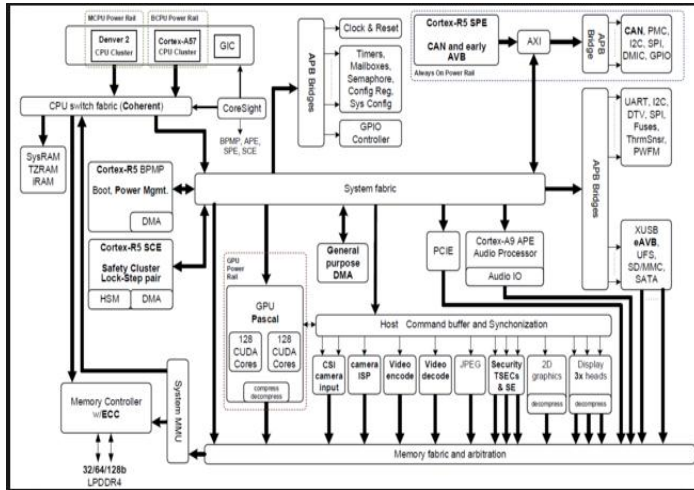

Fig.7 Block diagram Nvidia Jetson TX2 Tegra

## VI. CONCLUSION

There are different industries working towards the development of technologies used for design of the smartphones. Basically all the smart phones processors are designed with the ARM – based . Many advanced features like AI and Neural network are incorporated in the smart phones with the help of SoC and SiP technologies.

The new processors reduce the power requirement as well as it increases the efficiency of smartphones. It provide the security with the help of recent Block chain technology .

## REFERENCES

- [1] Mahendra Pratap Singh, Manoj Kumar Jain, Ph. D “Evolution of Processor Architecture in Mobile Phones” International Journal of Computer Applications (0975 – 8887) Volume 90 – No 4, March 2014
- [2] Masuma Akter Rumi,1 Asaduzzaman,1 D. M. Hasibul Hasan2 “CPU Power Consumption Reduction in Android Smartphone” 2015 IEEE
- [3] Nayeem Islam, Qualcomm , Roy Want, Google “Smartphones: Past, Present, and future”
- [4] Trevor Mudge “The Architecture of Smart Phones” 2015 IEEE 22nd International Conference on High Performance Computing
- [5] Steven Swanson and Michael Bedford Taylor, University of California “Green Droid: Exploring the Next evolution in Smartphone Application Processors”
- [6] Farinaz Koushanfar, Vandana Prabhu , Miodrag Potkonjak , Jan M. Rabaey ” Processors for Mobile Applications”
- [7] Alan Gatherer, Trudy Stetzler, Mike McMahan, and Edgar Auslander, Texas Instruments ”DSP based Architectures for Mobile Communications: Past ,Present and Future”
- [8] Dr. Margarita “Trends in Hardware Architecture for mobile Devices” Berlin November 2004
- [9] Masuma Akter Rumi,1 Asaduzzaman,1 D. M. Hasibul Hasan2 “CPU Power Consumption Reduction in Android Smartphone” 2015 IEEE
- [10] Leonid Ryzhynk “The ARM Architecture”
- [11] SoC Consortium “ ARM Processor Architecture”
- [12] Georgescu M.D. “Evolution of Mobile Processors “, communications , computers and signal Processing , 2003 PACRIM 2003 IEEE Pacific Rim conference.