

Condition Monitoring System of a Three Phase Induction Motor Against Thermal Overloading

Parthabrata Bhattacharjee^{1*}, Amartya Roy²

¹School of Illumination Science, Engineering & Design, Jadavpur University, Kolkata, WB, India

²Department of Electrical Engineering, Pailan Technical Campus, Kolkata, WB, India

Corresponding Author: *partha.bhatta123@gmail.com*, Tel.: +91 7980116633

Available online at: www.ijcseonline.org

Abstract— Cooling fan is used primarily to dissipate heat. All types of equipment with mechanical operations, regardless of industry sector, generate heat. For many machines, excess heat that is not rapidly and effectively dissipated can cause a shortened lifespan and even mechanical failure. Heat is capable of damaging a machine, sometimes irreversibly. The use of a cooling fan, therefore, is crucial for protecting the optimal functioning and the life of machinery. For this reason, cooling solutions like fans or blowers are widely used to enable equipment and machines to perform reliably. Cooling fans disperse hot air from within a machine and bring in cooler air from the outside so that the machine can work in optimal conditions. Some types of equipment use more than one fan to maintain a constant temperature. So in our project we are proposing a protective scheme for industrial motor from the phenomenon called thermal overloading.

Keywords— Temperature sensor; microcontroller; thermal overloading; induction motor.

I. INTRODUCTION

To control thermal overloading of a induction motor, there are two types of models, which are, firstly thermal model and secondly parameter based approach. This two process are used to eliminate motor temperature [1].

Thermal protection is needed in induction motor, to prevent the over-heating problem which is caused due to a cyclic and steady state overloads .A virtual temperature is set at which the tripping occurs, which protects the motors. The thermal model can only help in protecting motors in overload condition. But it fails, when it comes to distorted waveforms. Due to harmonics, the total losses in a system get increased, which causes the temperature to rise. In this problem the thermal model cannot be applied [2].

Adequate protection for motors is taken, by having many tests like locked rotor, phase unbalance and protection from overloads .Motor protection is often caused by temperature. So, good electrical & thermal model adoption is the only way to protect the motor from thermal overloading [3].

Heavy overload damages, the rotor bars of induction motor. The rotor bars are more affected by the raising temperature. There are many ways present in modern era, but most of them are too conservative and cannot adapt with the changing motor capacity [4].

Rotor and stator temperature of induction motor is of main concern both in case of short-term and long-term monitoring of large induction motor. It is necessary to monitor the temperature of rotor bars and stator windings, to ensure that temperature of these parts remains below prescribed limits [5].

The project consists of three parts; temperature sensor senses the motor temperature. Second part reads the LM35 sensor module's output and extracts temperature value into a suitable number in Centigrade scale and control the fan speed by using PWM. We are using a driver circuit to synchronize the AC fan with the microcontroller. NONC relay is used to cut the connection off while maximum thermal overloading. The third part of the system is when, NONC relay is off, and mechanical help is needed to switch on the relay, after that motor will start working.

II. PROPOSED MONITORING SCHEME

A: Block diagram of the system

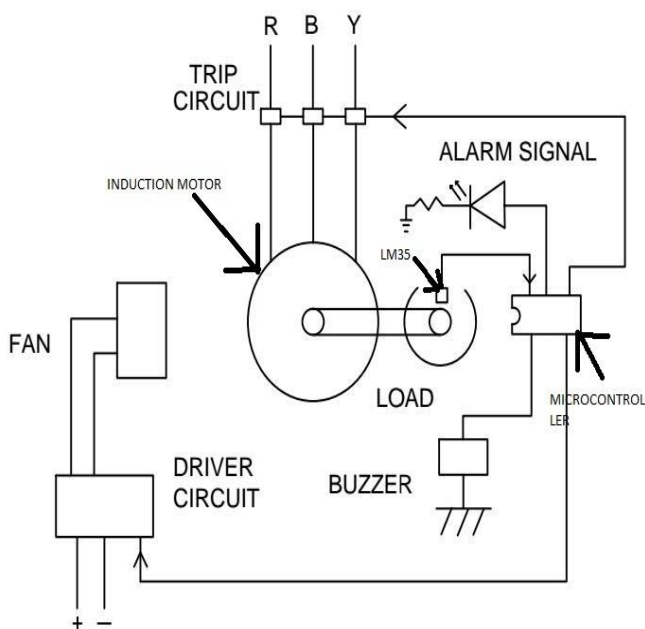

Figure 1. Block diagram of the monitoring system

It is block diagram of the proposed model; here we can see that the microcontroller is connected with a fan driver circuit along with a buzzer and an indicating lamp. Both the indicating lamp and buzzer works as an alarm signal. The temperature sensor LM35 is placed near the shaft of the motor.

As the temperature of the shaft increases, the temperature is recorded by temperature sensor. It is sent to the arduino microcontroller, where it gives triggering pulse to the fan connected with it. As per the temperature rise, the speed of the cooling fan also increases.

B: Calibration of temperature sensor

The Temperature sensor is one of the important components of our project. Calibration is done to see whether the component is working properly or not. From the data sheet we came to know that, voltage increases or decreases by 0.01V per degree rise or fall in temperature.

For the calibration of LM35, we placed it near a bulb of 200W which is connected with a variac. And the LM35 is placed 5cm near the bulb. Across the LM35 we connected a voltmeter. With linear increase of voltage in the bulb, there is linear increase of voltage in the temperature sensor.

When the same experiment is done in the Proteus software, we found corresponding temperature, for the corresponding voltage that we got from the practical experiment.

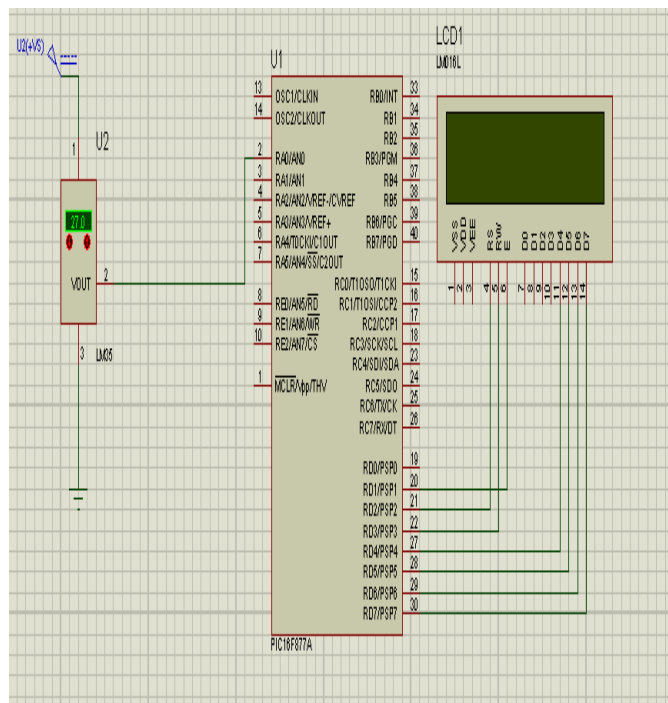

Figure 2. Circuit diagram in proteus software

In the diagram we can see that the temperature sensor is connected with a microcontroller & a LCD 16x2 is also connected. It is where the temperature sensor is calibrated in the proteus software. For the following temperature increase in the temperature sensor we can see the voltage in the LCD display.

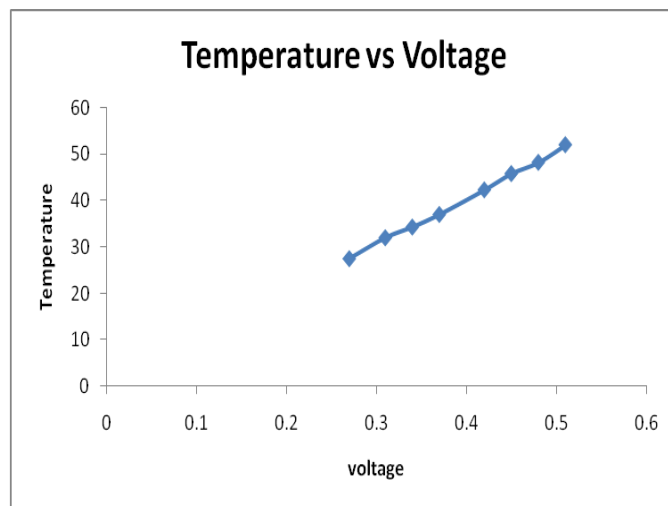

Figure 3. The graph between temperature and voltage of LM35

From the above graph with linear increase of voltage there is also linear increase of temperature in LM35. From the graph it is clear that with 1°C rise there is change 0.01V.

III. CIRCUIT ANALYSIS

This circuit provides protection with respect to temperature. Here, LM35 will sense the temperature of the motor. We have divided the obtained temperature from the motor into three categories.

Table-1: Boundary Condition

Case	Temperature (°C)
Stable condition	60-70
Under risk	71-80
Thermal Overloading	81-90

From the above table we can find that for three different cases three separate temperature boundary condition is set. Thermal Overloading takes place due to flow of huge amount of current. Flow of current increases or decreases due to loading and unloading of loads.

The induction motor that we have used in the experiment has class-B insulation. The temperature at which one motor can work without getting damaged is decided by the class of insulation used in the system. In Class B insulation the maximum temperature to which the motor can protect itself is 130°C.

We have used LM35 temperature sensor to sense the heat of the motor. It is placed 1cm away from the shaft. The reason to choose LM35 is that it works between temperatures -55°C to 150°C. So it can easily measure the temperature of the motor, having class B insulation.

The micro-controller that we have used is ATmega328P this is an Arduino Uno board. It has 6 pwm pin. All the components are connected with arduino board in different pins. In the pwm pins all triggering occurs.

One end of induction motor is connected with a 3 phase AC supply. In the three phase ac lines three NONC (Normally Open Normally Closed) relay is attached. This relay will act as a switch, so when the temperature will exceed the given 90°C, the circuit will be cut off. After that when the temperature comes down, with the mechanical help the switch is again closed.

We have used a .5KW induction motor having 1HP. The RPM of the motor is 1425 with 415V \pm 6%. It is 3-phase star connected induction motor ,having frequency of 50Hz.

A cooling AC fan is placed near the motor, which speed get increased or decreased according to the temperature of the induction motor. Fan is attached with the microcontroller with the help of driver circuit .The driver circuit consists of TRIAC and optocoupler. The fan is attached with the pwm pin of micro-controller. The temperature is sensed by the

temperature sensor LM-35, according to the temperature, a voltage originates. According to originated voltage the triggering pulse is send to the fan. The fan speed is directly related with the triggering pulse.

Apart from the motor and cooling fan and temperature sensor which is connected with the controller, more two things are also connected, an Indicating lamp and a Buzzer. The indicating lamp is off in the first stage that is during stable condition , in the second stage which is risk condition it is starting to glow with less brightness and during the last stage i.e. thermal overloading stage when the motors turns off , the led lamp glow at its optimum brightness . The buzzer comes in the last stage , it gives a continuous signal by giving sound. The sound goes on, temperature of motor goes down.

IV. ALGORITHM OF THE SYSTEM

- Step1: Start
- Step2: Initialization of cooling fan pin, LM-35 pin, 3phase induction motor, buzzer, indication LED
- Step3: Initialization of maximum and minimum temperature of LM-35
- Step4: Setting up of output pin for LM-35, motor and fan, buzzer, indication LED
- Step5: Temperature from LM35 is recorded.
- Step6: When the recorded temperature is more than 70°C the indication led started to glow
- Step7: When the recorded temperature is more than the maximum temperature, the Fan speed is the maximum but the motor is off, the indication led glows and buzzer also ON
- Step8: The buzzer remains on, till the temperature goes below 81°C , indication led will also glow at its full brightness till the temperature comes below 81°C . the led will be off when the temperature of the motor goes below 71°C
- Step9: The induction motor will again work when the NONC relay switched on with help of mechanical support which is placed in each phase of the motor.
- Step10: End

V. CONCLUSION AND FUTURE SCOPE

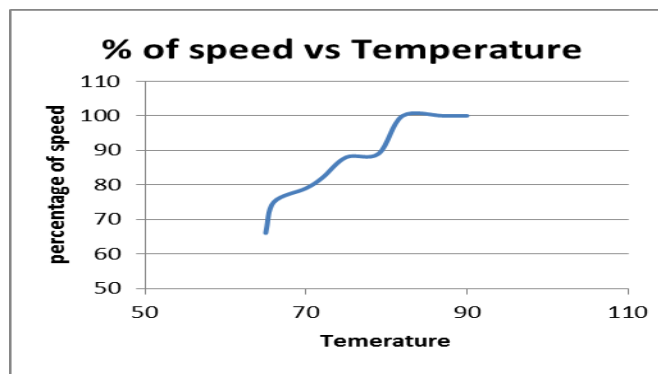

Figure 4. graph against percentage speed of fan and temperature

The graph is obtained by putting uneven loads on the shaft of motor. Due to putting of uneven loads on the shaft, there is flow of currents, which causes the temperature to increase. In the graph we can see that the corresponding rise of temperature, the speed of cooling fan also increases. It is the maximum when the temperature of the motor reaches around 90°C. The fan speed is the maximum till the temperature of motor is between 81°C to 90°C

VI. CONCLUSION AND FUTURE SCOPE

The result from the experiment is satisfactory. Inside few machines a cooling fan is already present. But by connecting another cooling fan externally it will increase the protection of the machine. It will ensure more safety. If the cooling fan inside the machine gets faulty, it needs more time and man power to change the faulty part, whereas here the fan is connected externally so we can easily change the faulty part in less time.

Here the experiment is done, for protection of induction motor. But this model is applicable to any machine, whose temperature increases with rate of loading and unloading of loads.

Here temperature sensor is placed 1cm away from the shaft so that it can detect the temperature of the motor. But the LM35 is gets affected by the room temperature . So in future, if temperature sensor and shaft is covered separately, it will give more precise reading and protection of the machine will also be increased.

If number of temperature sensor is increased it will detect the temperature more precisely, that will benefit the protection of the system. DHT - 22 sensor can be also be used in place of LM35 where the advantage is that the humidity as well as temperature can both be controlled. DHT - 22 sensor accuracy is also more than that of LM35 sensor. But, the main disadvantage of this sensor is that it can work till 50°C. So it is applicable only for protection of small machines.

ACKNOWLEDGMENT

Thanks to the Department of Electrical & Electronics Engineering, Pailan College of Management & Technology. Special thanks to Prof. (Dr.) Nirmalendu Chatterjee, Ex Professor of Electrical Engineering Department, Jadavpur University, Kolkata-32 & Prof. (Dr.) Biswanath Roy, Professor of Electrical Engineering Department, Jadavpur University, Kolkata-32

We have done this project on the final semester of our B.Tech career. I am very thankful to my classmates and teachers, without them we could not have written this paper.

We are also thankful to Mr. Sanjoy Halder, Assistant Engineer, KMC for his continuous help whenever we required.

REFERENCES

- [1] Du, Y., Habetler, T.G., Harley, R.G.: Methods for thermal protection of medium voltage induction motors ----A review-condition Monitoring and Diagnosis, 2008. CMD 2008
- [2] Khederzadeh, M., thermal overload protection of induction motors under waveform distortion-universities power engineering conference, 2006. upec '06. proceedings of the 41st international,2006
- [3] Zocholl, S.E., Schweitzer, E.O., Zegarra, A.A.: Thermal Protection of Induction Motors Enhanced by Interactive Electrical and Thermal Models- IEEE Power Engineering Review (Volume: PER-4, Issue: 7, July 1984)
- [4] Du, Y., Zhang, P., Gao.Z. Habetler, T.G.: Assessment of available methods for estimating rotor temperatures of induction motor- Electric Machines and Drives Conference, 2009. IEMDC '09. IEEE International
- [5] Beguenane, R., Benbouzid, M.E.H.: Induction motors thermal monitoring by means of rotor resistance identification-IEEE Transactions on Energy Conversion (Volume: 14, Issue: 3, Sep 1999)

Authors Profile

Mr. Parthabrata Bhattacharjee, B.Tech (WBUT) in Electricla & Electronics Engineering. He is currently pursuing M.Tech.(Jadavpur University) in Illumination Science & Technology. He has published few conference papers on Illumination Science and renewable energy.Presently working on Lighting simulation tools like DIALux, Ecotect and LightTool. His main research work focuses on Luminaire design and Daylight Pipe (DLP).



Mr. Amartya Roy, B.Tech (WBUT), M.Tech (Jadavpur University), Working as an Assistant Professor from Department of Electrical Engineering, Pailan Technical Campus, Kolkata - 104. He has published more than 5 research papers in reputed international journals including Thomson Reuters (SCI & Web of Science) His main research work focuses on condition monitoring system, illumination engineering He has 7 years of teaching experience and 2 years of Industry Experience.

