

Cost Minimization Based Multi Way Automatic Changeover

Anirban Giri^{1*}, Debabrata Hazra²

^{1,2}Dept. of Electrical Engineering, MODERN INSTITUTE OF ENGINEERING & TECHNOLOGY, Bandel, India

Corresponding Author: anirbangiri2016@gmail.com

Available online at: www.ijcseonline.org

Abstract— This article proposes a Cost minimizing based multi-way automatic changeover. Use of automatic multi-way change over will reduce the waste of money and also reduce the use of non-renewable energy. This process can be able to find out the most profitable source at any instant of time and able to derive the load from that source. The proper uses of relay and micro controller system reduce the time of switching. The proper relay logic ensures the proper isolation between sources. Any error signal generated by the controller cannot affect on the isolation of the sources. An LED monitoring system makes the system user friendly. The proposed changeover can able to handle more than 2 sources. It can work considering under voltage protection and try to supply power uninterruptedly to the load. The changeover always tries as much as it can use the available renewable energy source to drive the load. The proposed system will never disconnect the load to the source at any condition.

Keywords—Distributed Generator (DG), Series relay logic, isolation between different sources.

I. INTRODUCTION

Power failure is a major problem in developing country. Power failure causes of lack of energy. To prevent the power failure we need alternative source. Frequent power cut is a major problem in some important places like hospital, research lab etc. Automation is essential for continuously supply of power. Most of cases changeover systems are dependent on manually. It is a time consuming process. For this we need automatic changeover process. By developing the technology we need proper utilization of power. This purpose can be fulfilled by designing multi-way automatic changeover. Nowadays use of renewable energy and proper utilization of power is very essential. If we have more than 2 different sources it is very difficult to selection of source for a particular instant of time for a machine by considering the economical profit of consumer. The proposed system always tries to select the source which power has low cost, which can supply the voltage greater then safe label. If there are 2 sources it is possible to change the source by an automatic changeover. Basically this changeover are 2 way. This changeover has the ability to start a DG automatically and connect the load to it. But the problem is that in automatic change over the load is connected to the DG terminal and DG starter turned on at a time. If we connect a load to a generator at starting time it is not good for the generator health. By using this multi-way automatic changeover this problem can be resolve, After turning on the DG it will wait for connecting the load to DG until the rated voltage build up . If we have 3 or more than 3 source for changeover system we use rotor switch, it operates manually. So we need a

person at control room. The selection of source by rotary switch can be operated by manually. So the user must study the voltage of all the sources and decide which should be the proper supply. If it is manually operated, this is time consuming. The manually operated changeover system has some drawbacks like-it generate large noise the time of switching, delay occurs in the time of switching so power cut for sometime occurs, External mechanical energy needed to change the source. In case of rotary switch the switch life is not too long. The main drawback of rotary switch is we have to change source simultaneously, we cannot able to jump another source .By using multi way automatic changeover this problem can be resolve. This system has good efficiency, low cost, high speed switching, less noise, easy to maintenance, total indicator system, easy development option and proper isolation between 2 sources. A proper designed low voltage protection system ensure the under voltage protection.

II. WORKING

This system always tries to gives us economically profit. At the building stage we define the source name and cost and other specification. System is controlled by Arduino micro-controller. Each individual source gives it voltage level to the Arduino by a potential transformer through a rectifier and voltage comparator. Here we can select minimum voltage level individually for each source to protect the instrument from low voltage.

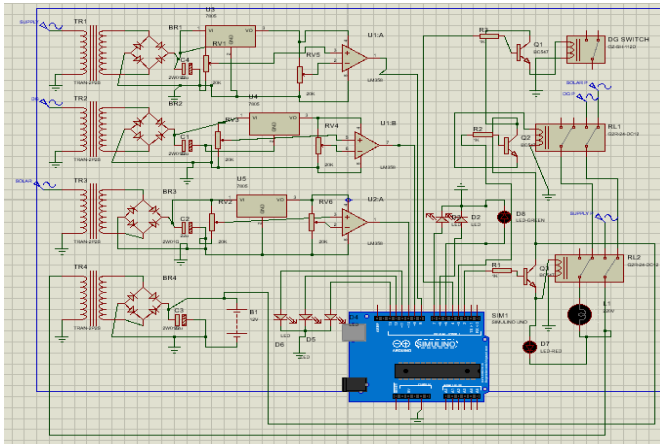

Figure 1. Schematic diagram of the system

III. PROCESS OF WORK

This changeover continuously checks all the voltage level of each Source. Now it will check the sources which are over the selected voltage level, means the source that can able to drive the load properly. After gating this data the system will calculate where the user will get more profit and select the source. By using relay mechanism the load is connected to that source. If there is no source to gives the proper voltage level then it will turn on DG and wait until the DG gives the proper voltage. In the DG turning on time to continue the load operation it will connect the load to other in sufficient source. When the DG gives proper voltage level it will connect the load to the DG. At DG running time if it gets other supply at proper voltage level it will at first transfer the load from DG to that source and then turn off the DG. If the DG is not able to supply the voltage over the selected under voltage, then the system will connect the load to other low voltage source to drive the load contentiously.

This changeover has monitoring systems which are divided into two part voltage monitoring (which are display the source, are at proper voltage level and available source indicator.) & LOAD indicator (indicate the supply where the load is connected).

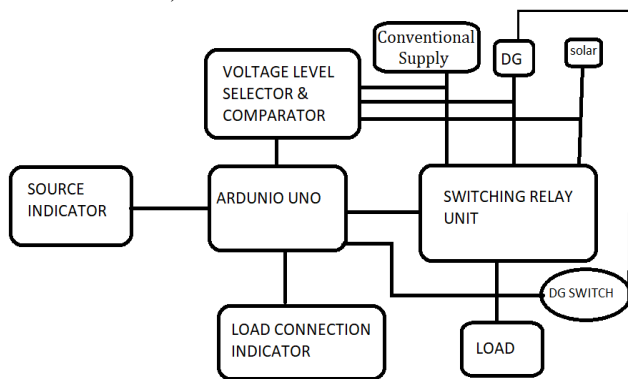

Figure 2. Block diagram of the system

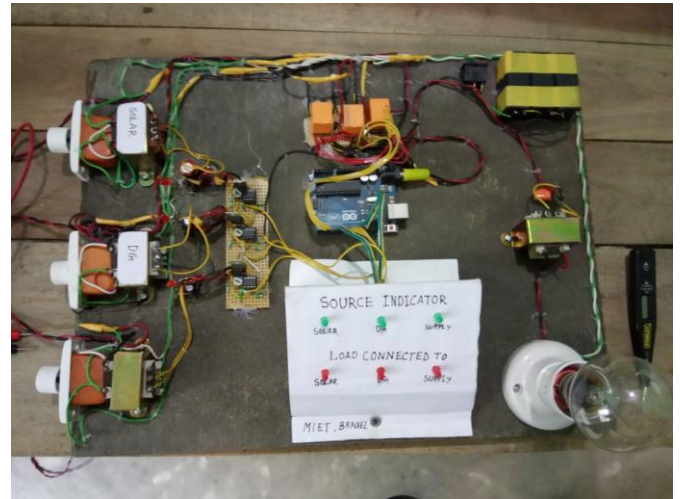

Figure 3. Hardware model of the system

IV. SERIES CONNECTION RELAY LOGIC

From 3 or more than 3 supply when we operate a common load keeping only one supply connected to load, sometime it is very difficult to isolate a source from each other. At the switching time short circuit between 2 sources may occurs. By using series relay logic and double through relay the chance of short circuit is totally reduced.

If there are n number of source the number of relay required is (n-1)

Connection Relay1 common terminal to load Relay1 NC + source1, Relay2 NC + source2.....Relay(n-1)NC + source(n-1) & Relay(n-1)NO + source n
 Relay1NO+Relay2common,Relay2NO+Relay3common.....
Relay(n-2)NO+ Relay(n-1)common.

By using this connection probability of short circuit between 2 sources is zero. The system is mainly designed for single phase 7A AC supply. To use at high current only the relay module will be replaced. To use the system in 3-phase the relay pole will be increased as required. It can also be used in poly phase by increasing the number of pole in relay.

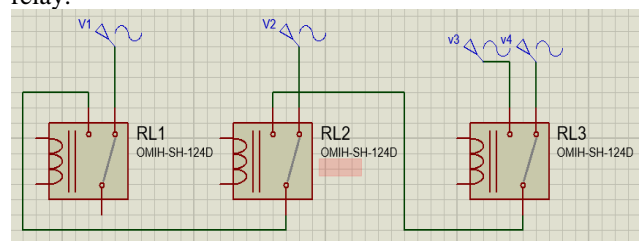

Figure 3. Series relay logic

V. RESULTS AND DISCUSSION

The system tested over 50 times. In testing period no fault occurs. The load was 60W. No extra noise found in the

system & indicators are working properly. At the time of DG starting it waits until the DG is not giving the proper voltage. When all the entire sources are under low voltage then the change over connects the load to the low voltage conventional supply to drive the load continuously.

Table 1. Testing result table

Sl. No.	Solar	Conventional Supply	DG	Load connected from
1	230	230	0	Solar
2	180	230	0	Supply
3	180	180	230	DG
4	180	180	180	Supply

VI. CONCLUSION AND FUTURE SCOPE

The paper has introduced the proper application of micro controller to utilize renewable energy properly. This system is fully isolated between 2 different sources. The feedback system and voltage comparison system of the multi-way automatic change over will not allow to connect load to DG before starting or at starting time. Nowadays in residential building supply, solar and DG are available, so this automatic system can applicable for these building and it will minimize the use of non renewable energy. This result is satisfactory and promising for domestic and commercial uses

REFERENCES

- [1] Nwafor Chukwubikem M. ,Mbonu Ekene S. ,Uzedhe Godwin "A COST EFFECTIVE APPROACH TO IMPLEMENTING CHANGE OVER SYSTEM ", Academic Research International, Vol.2, No.4, pp.62-72, 2012.
- [2] Obasi,Chijioko Chukwuemeka,Olufemi Babajide Odeyinde,John Junior Agidani,Victor Onyedikachi Ibiam,Ubadike,Chiedu Osichinaka "Design and Implementation of Microcontroller Based Programmable Power Changeover", Computer Engineering and Intelligent System, Vol.6,No.12, pp.51-56, 2015.
- [3] M.S. Ahmed, A.S. Mohammed, O.B. Agusiobo "Development of a Single Phase Automatic Change-Over Switch", AU J.T, 10(1), pp. 68-74 , Jul. 2006.