

Design of Driverless Pod Using Voice Commands : A Novel Approach

Swastik Bhattacharya^{1*}, Moloy Dhar², Srotoswini Chanda³

^{1,2,3}Department of Computer Science and Engineering, Gurunanak Institute of Technology, Kolkata, India

Corresponding Author: *swastikbhattacharya.007@gmail.com, Tel.: +91-8420668976*

Available online at: www.ijcseonline.org

Abstract— The Internet of things (IoT) refers to the concept of extending Internet connectivity beyond conventional computing platforms such as personal computers and mobile devices, and into any range of traditionally "dumb" or non-internet-enabled physical devices and everyday objects. Embedded with electronics, Internet connectivity, and other forms of hardware (such as sensors), these devices can communicate and interact with others devices over the Internet, and they can be remotely monitored and controlled. Specifically, when the automations are needed to be controlled using just voice commands from a remote location, that may be a large distance. This paper also includes detection of obstacles and the device come to a stop/waiting for the voice command from the control room (which is in remote location) and then take next decision.

Keywords—:IOT,wi-fi,Motionestimation,IR

I. INTRODUCTION

IoT devices are a part of the larger concept of home automation, which can include lighting, heating and air conditioning, media and security systems. Long term benefits could include energy savings by automatically ensuring lights and electronics are turned off. The IoT can assist in the integration of communications, control, and information processing across various transportation systems. Application of the IoT extends to all aspects of transportation systems IOT is an upcoming technology that allows us to control cars through the internet. Here we propose to use IOT in order to control car through the internet. This system uses a small electronics car to demonstrate the model. Our user friendly interface allows a user to easily control this car through the internet. For this system, we use nodeMCU wifi module, a 8051 microcontroller, motor drivers, rf modules etc. This module is interfaced with a wi-fi modem to get user commands over the internet. The entire system is powered by a 12 V battery. After receiving user commands over the internet, nodeMCU processes these instructions to operates the car using motor drivers with sending wireless alert to the control room.

The remainder of this paper is organized as follows.

II. STATE OF THE ART

The basic concept of an Infrared Sensor which is used as Obstacle detector is to transmit an infrared signal, this infrared signal bounces from the surface of an object and the signal is received at the infrared receiver. The basic concept of IR (infrared) obstacle detection is to transmit the IR signal

(radiation) in a direction and a signal is received at the IR receiver when the IR radiation bounces back from a surface of the object[1]. Here in the figure, the object can be anything which has certain shape and size, the IR LED transmits the IR signal on to the object and the signal is reflected back from the surface of the object. The reflected signals are received by an IR receiver. The IR receiver can be a photodiode / phototransistor or a readymade module which decodes the signal. In order to implement the IR obstacle detection, we need to understand the following:

We need to understand how to transmit IR signal using commercially available electronic components. Same way we also need to understand the IR receiver. Our main focus in this paper is to explain the implementation of IR based obstacle detection in detail.

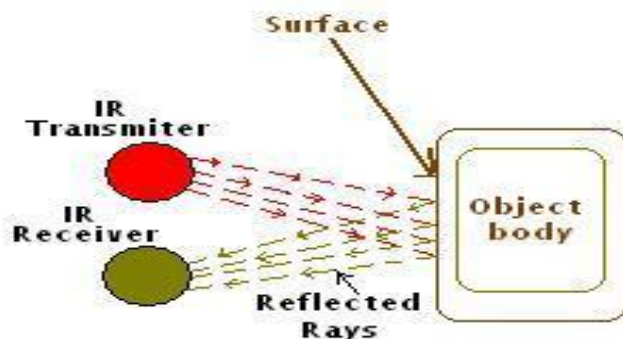

Fig. 1

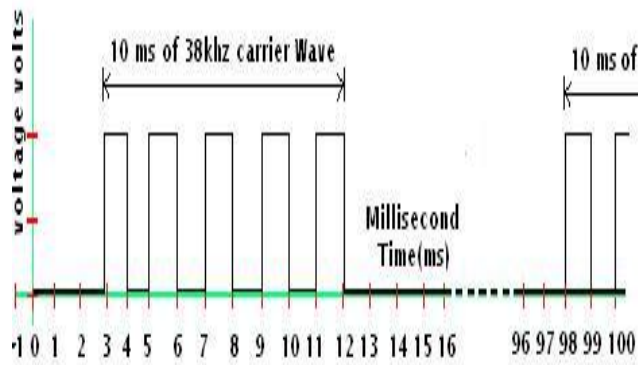

Fig. 2

IR Transmitter

In general, the basic building block of any IR transmitter is modulation of the information signal with carrier signal, because the receiver modules which are available off-the-shelf are made for a particular carrier frequency. So it is clear that when we chose a particular IR receiver module, we also need to transmit the the modulated wave with the same carrier frequency of that of a IR receiver module.

Modulating a 38 KHz carrier signal

ON state = 10ms

OFF state = 90ms

The figure above explains the modulation process, this is similar to OOK(ON-OFF Keying) modulation, where the carrier signal is ON for certain period of time. When transmitting a signal for obstacle detection, it is necessary that the carrier signal is transmitted for a short while and remains OFF for longer period of time[2].

If the transmission of the carrier signal is prolonged, in other words, instead of having a short transmission period(10 milliseconds in our case, as explained in the figure) of carrier signal, if we have it for a long period of time then the receiver module will treat it as a noise and ignores receiving the transmitted signal.

III. OUR PROPOSED TECHNIQUE

The implementation of IR transmitter can be done in various ways; in this paper we will discuss two ways

- Using 7555(compatible with 555) timer IC to generate a 38 kHz carrier signal
- Using Micro controller(Atmel atmega8535) inbuilt wave generation module

Now let us have a look at the IR transmitter using 7555 timer IC

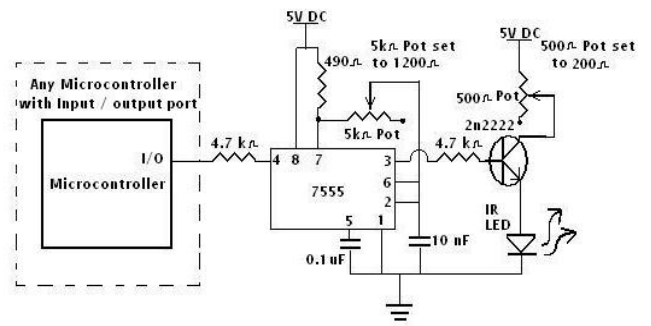

Fig. 3

IR Receiver

It is quite simple to construct a IR receiver with readily available off-the-shelf modules. These modules are nothing but the IC packages, referred as TSOP (Thin small-outline package). In this document, the receiver is designed for 38 kHz carrier signal; hence the IC selected should work for the same frequency. The IC TSOP4838 will serve as a receiver module, which is compatible with both TTL and CMOS logic. This means that we can directly get digital signal from the receiver module and then connect it to the microcontroller.

The Implementation of IR receiver is explained using an LED as an indicator.

Here in the circuit the LED blinks whenever the TSOP4838 module receives a signal from the transmitter. The same circuit can be altered to work with microcontroller; the circuit below has both IR transmitter and IR receiver modules integrated with the microcontroller.

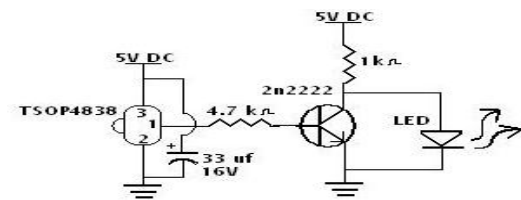

Fig. 4

IR SENSOR & MONOSTABLE

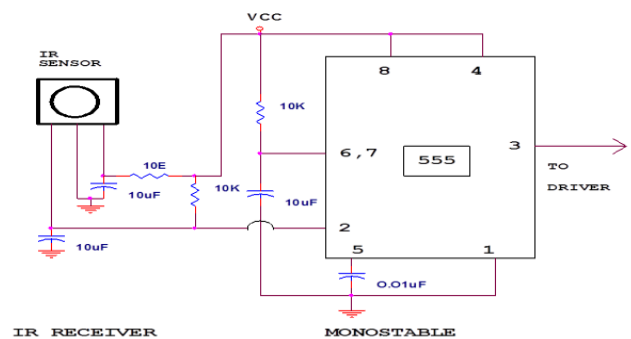
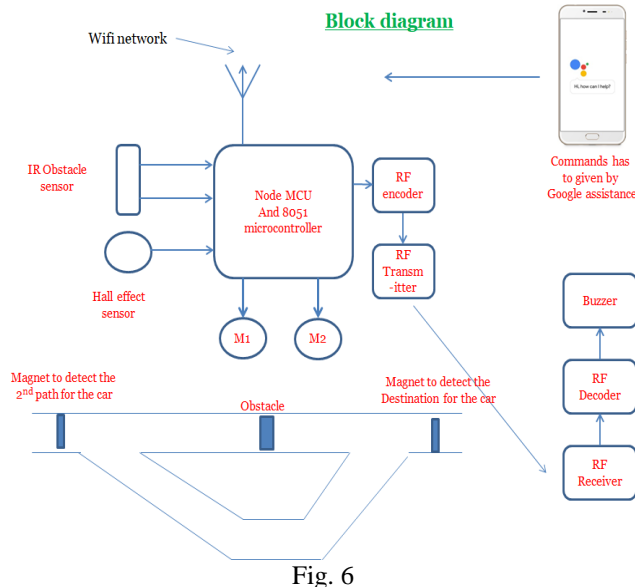

Fig. 5



IV. RESULTS AND DISCUSSION

Using Google Assistant we are able to readily convert the given voice commands into actual texts which can be interpreted by Ardafruit. This has brought down the time taken to physically write down the commands by a tremendous percentage.

V. CONCLUSION AND FUTURE SCOPE

This work has a vast field for expansion. The controller is designed with latest technology of communication and control. This model is designed with constraint of time and cost. This model can be modified and expanded in the following fields, The controller can be interfaced to with sensor to send back the information to the user regarding its initial position[5][6].

The music generator can be replaced with multiple voice stack, so a status message can be send back to the user[6].

Multiple devices can be controlled by single command.

A timer base control unit can be developed so that ON TIMER and OFF TIMER can be implemented A SMS base protection system or security system can be combined with this Design[4]. The system is designed in the laboratory and tested in the laboratory condition. It is observed that the system is operating satisfactorily with a very minimum error which is quit less than the experimental tolerance level. The design is quite stable and economical.

A. Abbreviations and Acronyms

- IOT-Internet Of Things
- Wi-Fi-Wireless Local Area Network
- IR-Infrared
- nodeMCU-System of Chips

- LED-Light Emitting Diode
- TSOP-Tiny Small Outline Packages

B. Units

- Hertz

ACKNOWLEDGMENT

Firstly I would like to thank the people who have contributed tremendously in the project the names being Sayantony Dey, Sukanya Rakshit and Subham Banerjee. Secondly my co-author Srotoswini Chanda without whom I would not have been able to complete the paper in time. Lastly I would like to thank my parents for their continued and undying support.

REFERENCES

- [1] Christie, Derek & Koymans, Anne & Chanard, Thierry & Lasgouttes, Jean-Marc & Kaufmann, Vincent. (2016). Pioneering Driverless Electric Vehicles in Europe: The City Automated Transport System (CATS)
- [2] Kohl, Christopher & Knigge, Marlene & Koleva, Galina & Böhm, Markus & Krcmar, Helmut. (2018). Anticipating acceptance of emerging technologies using twitter: the case of self-driving cars. Journal of Business Economics. 10.1007/s11573-018-0897-5.
- [3] Pendleton, Scott & Uthaicharoenpong, Tawit & Jie Chong, Zhuang & Ming James Fu, Guo & Qin, Baixue & Liu, Wei & Shen, Xiaotong & Weng, Zhiyong & Kamin, Cody & Adam Ang, Mark & Tetsuya Kuwae, Lucas & Marczuk, Katarzyna & Andersen, Hans & Feng, Mengdan & Butron, Gregory & Chong, Zhuang Zhi & Jr, Marcelo & Frazzoli, Emilio & Rus, Daniela. (2015). Autonomous Golf Cars for Public Trial of Mobility-on-Demand Service. 10.1109/IROS.2015
- [4] J. Haboucha, Chana & Ishaq, Robert & Shiftan, Yoram. (2017). User preferences regarding autonomous vehicles. Transportation Research Part C: Emerging Technologies. 78. 37-49. 10.1016/j.trc.2017.01.010.
- [5] Szigeti, Szilárd & Csiszar, Csaba & Földes, Dávid. (2017). Information Management of Demand-responsive Mobility Service Based on Autonomous Vehicles. Procedia Engineering. 187. 483-491. 10.1016/j.proeng.2017.04.404.
- [6] Monjezi Kouchak, Shokoufeh & Gaffar, Ashraf. (2018). Determinism in Future Cars: Why Autonomous Trucks are Easier. 10.1109/UIC-ATC.2017.8397598.

Authors Profile

Mr.Swastik Bhattacharya has completed his Bachelors in Computer Science And Engineering in the year 2019

Ms Srotoswini Chanda has completed her Bachelors in Computer Science And Engineering in the year 2019

Mr Moloy Dhar is currently an Assistant professor at Gurunanak Institute of Technology.