

## Automated upper dipper by Sensing light intensity

Chandni Raut<sup>1\*</sup>, Komal Dhok<sup>2</sup>, Parul Jha<sup>3</sup>

<sup>1,2,3</sup>Dept. of Computer science Engineering, Jhulelal Institute of Technology, Rashtrasant Tukdoji Maharaj Nagpur University, Nagpur, Maharashtra

Corresponding Author: chandaniraut1998@gmail.com

Available online at: [www.ijcseonline.org](http://www.ijcseonline.org)

**Abstract**— Automatic upper dipper using light dependent resistor(LDR) while driving a vehicle in the night many drivers do not dip the head lamps of their vehicles in night while approaching. Several switching operation is used to dip the head light which may distract the concentration. one of the essential safety feature that need to be installed is automatic upper dipper control of headlight. Headlight of vehicles pose a great danger during night driving. The drivers of most vehicles use high, bright beam while driving at night. This causes a discomfort to the person travelling from the opposite direction and therefore experiences a sudden glare for a short time this is caused high intense headlight beam from the other vehicle coming towards the one from the opposite direction. In this project an automatic headlight dimmer which use a light dependent system (LDR) sensor has been designed to dim the headlight of on-coming vehicles to avoid human eye effected. This automatically switches the high beam into low beam, therefore reducing the glare effect by sensing the light intensity value approaching vehicle and also eliminates the requirement of manual switching by the driver which was not done at all time.

**Keywords**—Automatic control, headlight ,upper , dipper

### I. INTRODUCTION

Now days the number of vehicles on road is increasing drastically and number of accidents on road also increases.Especially at night most of the accidents are occurred due to dazzling of high light.

While driving at night the headlight beam of oncoming vehicle is directly effect the driver eye and eye gets blur, it takes 3 to 8 seconds to recover to its normal vision .The high beam of headlight which causes blurriness on drivers eye to prevent all these drawbacks we design a new system that is automated upper dipper by sensing light intensity.

Most of the accidents are happened in night due to glaring effect to eyes due to upper mode of headlight of upcoming vehicle. To overcome this glaring effect an average human eye need some seconds which may be one of reason for accidents.

Driving in the highway with your high-beam headlight can really increase your visibility but can be a blinding hazard for other drivers.this simple circuit can be wired into your headlight switch to provide automatic switching between high and low beam headlights when there is oncoming traffic in this way,you can drive safely with your high beam on without blinding other drivers .

### II.RELATED WORK

#### 2.1 Automatic Dipper Light Control for Vehicles

Operating principle, working and design of PCB idea is briefly discussed in this paper. Many times the situation comes when suddenly vehicle approaches from front with headlight in upper mode causes blindness to the eyes of the driver. During that time vehicle covers some amount of distance, here chances of accident may occur. It is a sheer luck if person goes safely through that situation. To overcome this manual dipping problem, an automatic mechanism has made to dip the headlight automatically whenever situation occurs. This can reduce number of accidents during night time and provide comfortable driving. [1]

#### 2.2 Automatic Dipper Circuit for Vechicle using AT89S52 Microcontroller

The Automatic dipper can perform a great deal in reducing the manual efforts and fatigue of drivers in dipping the headlamp frequently while driving through highway full of moving vehicles.. And when the highway will be full of vehicles, trucks, buses and even the two-wheelers. The implementation of this device in every vehicle in future will not only avoid accidents but also provide a safe and a comfortable driving.

#### 2.3 Automatic Dipper System

While driving a car in night a problem like many drivers do not dip the head lamps of their vehicles in night while approaching. The several switching operation is used to dip the head light which may distract the concentration. To overcome this type of problem the innovative group Dreamlover Technology designs a unique electronics gadget called “Automatic Dipper” using very popular IC NE555 and LDR.

**Circuit Description**

The entire circuit of automatic dipper consist LDR followed by timer IC NE555 (IC1) and few other components, where LDR is used as sensor. LDR sense the light a7nd change its internal resistance according light fall on it, which is further mounted in PVC pipe of 4 cm length positioned on the grill of car or in front such that the light fall on the LDR only when vehicles is approaching and is distance of 3M to 9M. When light fall on it the resistance decrease and makes output of IC1 low which energized the relay.

The relay operates and voltage across the head lamps is reduced. When the distance between two approaching vehicles is more than 9 meter or less than 3 meter the circuit is not operated

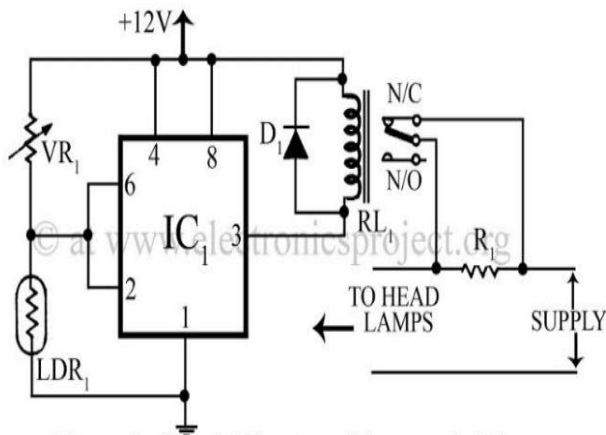

Figure 1: Circuit Diagram of Automatic Dipper

**2.4 Automatic Upper Dipper Light Control**

Komal shinde:-Driving the highway with your high-beam headlights can really increase your visibility, but can be a blinding hazard for other drivers. This simple circuit can be wired into your headlight switch to provide automatic switching between high and low beam headlights when there is oncoming traffic.

It does this by sensing the lights of that traffic. In this way, you can drive safely with your high-beams on without blinding other drivers.

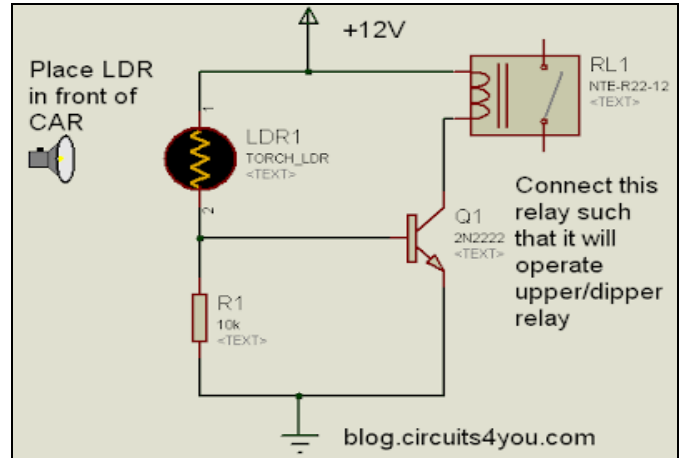

Fig.2 Circuit Diagram of LDR

**2.5 What does upper/dipper mean while driving**

Akshay Nayak:-While driving it’s always recommended to use dipper more often and upper should be used only if necessary. The reason is because while driving at night visibility is low on roads without streetlights and to counter this drivers tend to use upper which also means high beam.

The car headlight bulb has two modes high beam and low beam also known as upper and dipper. On low beam the reach of the light is less and the bright is also low but sufficient to drive with. Whereas, in upper or high beam, the light is much more intense and the reach is much better as the light is projected at a higher height too which affects the car’s drivers coming from opposite direction. This can cause them to have poor visibility because of the excess light hitting their eyes. To counter that they also switch to High beam which affects others and this is a dangerous cycle and leads to accident in many narrow roads.

**III. PROBLEM STATEMENT**

There are many problems faces by the people while driving so to overcome this problems we introduce a new system automated upper dipper by sensing light intensity. Firstly the sensor senses the intensity of light in the environment .After that according to the light intensity, upper or dipper light is automatically on. Using this system we can control the problems occure from upper dipper light in the vehicle properly .

**IV. PROPOSED SYSTEM**

The 555 timer IC is the main control of this system and it is mainly known for generating stable time delays. here for this

system ,monostable mode is used for developing the timing logic.it is an 8 pin IC available in dual in package (DIP) .

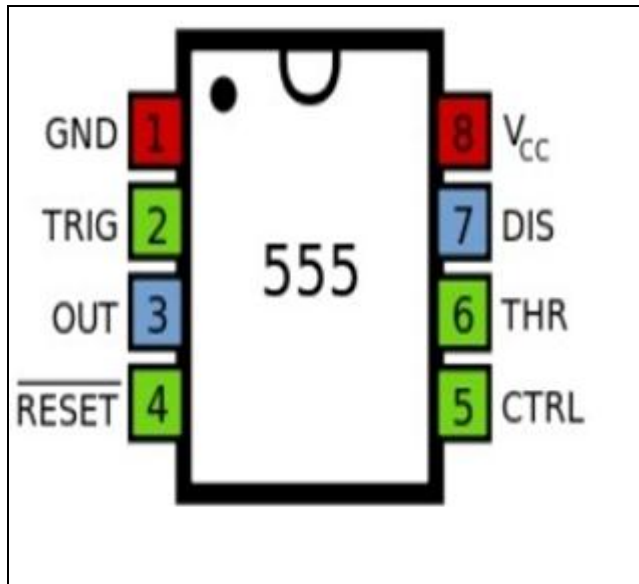

Fig.3. Pin Diagram of IC555

In this system relay is used as switch to change the lamp connections from upper beam to dipper beam.relay is electromagnetic switch which operates when current is flowing through its coil. Connection of upper beam is given to NC (normally close) terminal.

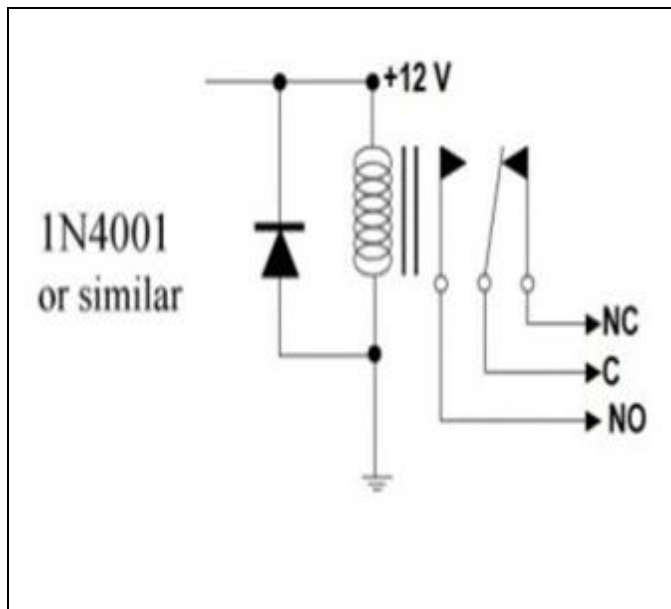

Fig.4. Relay Driver

It is nothing but a photo sensor or photo resistor i.e. when the light fall on these LDR's then the resistance of the circuit changes accordingly with the change in intensity of light.

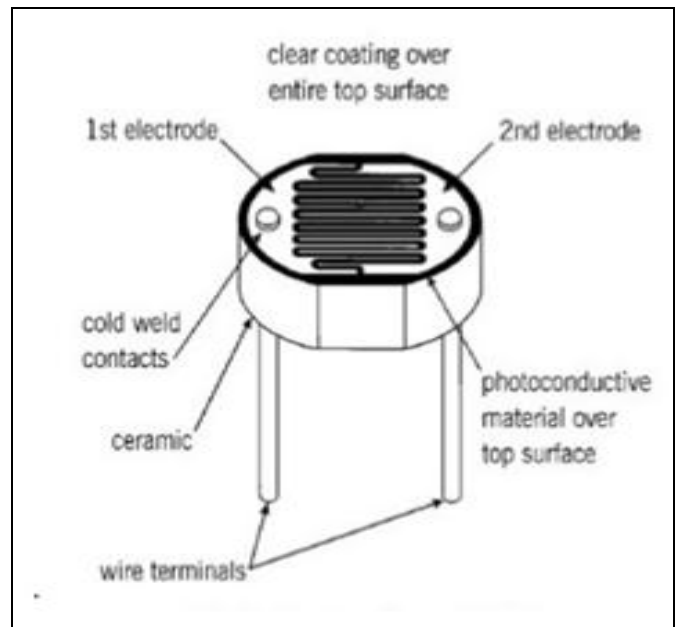
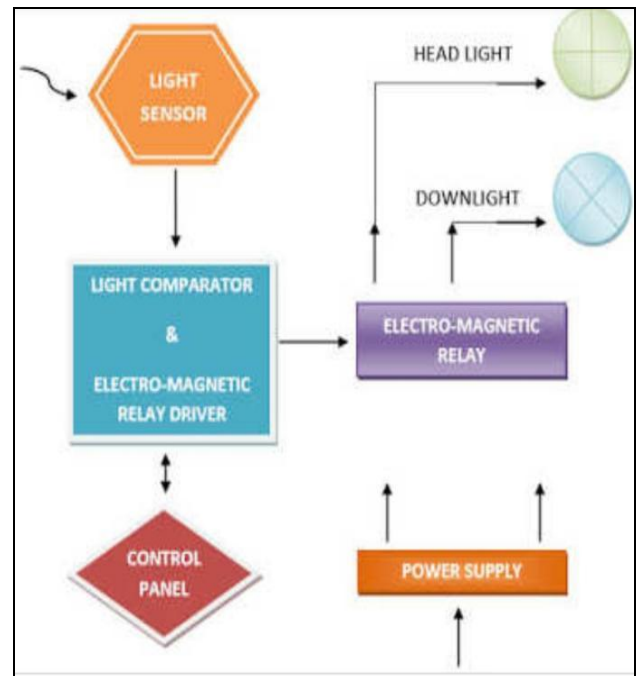

Fig.5. Construction of LDR

V. FLOW DIAGRAM



Conclusion And Future Enhancement

VI. Conclusion

Automatic upper dipper by sensing light intensity provide better safety at night time and drivers can drive comfortably

and reach their destination safely. Automated upper dipper by sensing light intensity can control the accidents. Sensing the opposite vehicles bright headlights automatically and after giving them a notification and according to their response whether they dipps of Light.

## VII. FUTURE ENHANCEMENT

In future we can use this technology for heavy vehicles such as trucks, buses, etc

## REFERENCES

- [1] Tejas Vijay Narkar , “AUTOMATIC DIPPER LIGHT CONTROL FOR VEHICLES “, IJRET pISSN: 2321-7308
- [2] Udaya Sharma<sup>1</sup> , Deepak Rasaily<sup>2</sup> , Tashi Rapden Wangchuk, <sup>3</sup> Ankita Pradhan <sup>4</sup> Kiratti Upashna ,”Automatic Dipper Circuit for Vechicle using AT89S52 Microcontroller” IJETT – Volume 33 Number 8- March 2016
- [3] [www.autodipper.com/concept.html/](http://www.autodipper.com/concept.html/)
- [4] [www.electronicproject.org/automatic-dipper-for-vehicles/](http://www.electronicproject.org/automatic-dipper-for-vehicles/)
- [5] [http://en.wikipedia.org/wiki/555\\_timer\\_IC/](http://en.wikipedia.org/wiki/555_timer_IC/)
- [6] <https://en.wikipedia.org/wiki/Photoresistor>
- [7] [https://learn.sparkfun.com/tutorials/switch\\_basics/poles-and-throws-open-and-closed](https://learn.sparkfun.com/tutorials/switch_basics/poles-and-throws-open-and-closed)
- [8] D. Roy Choudhary, “Linear Integrated Circuits”, 4th ed. New Age International Publishers ,p p 311-31