

Modified Load Flow Analysis in Unbalanced Radial Distribution System

Surender Singh^{1*}, V.R Singh², R.Ranjan³

¹ Electrical Engg., UIET, Maharshi Dayanand University, Rohtak, India

² Electrical Engg, PDM, Maharshi Dayanand University, Rohtak, India

³ Electrical Engg.,IITB, DCURT University, Sonapat, India

*Corresponding Author: Surender.b1985@gmail.com

Available online at: www.ijcseonline.org

Accepted: 17/Jul/2018, Published: 31/July/2018

Abstract— In this paper a modified load flow algorithm is applied in unbalanced RDS to determine the exact power losses, voltage at each node and enhance the efficiency of unbalanced load flow solutions. In this paper, an attempt has been made to minimize real power loss with existing unbalanced radial distribution systems. The proposed method has been tested on several radial distribution systems and results found are noteworthy. The results are compared with existing methods for 25-IEEE node URDS system and a noticeable change in the power loss and node voltages were observed.

Keywords— Modified unbalance load flow analysis (MULFA), radial distribution system, Real power loss (RPL).

I. INTRODUCTION

Today there is need of power in industrial, domestic and commercial goes on increasing day by day. For the increase in power demand we need load flow as a tool of analysis to get the line flows in distribution system. Many authors have been proposed the modern load flow method with different parameter and constraints.

The mesh and unbalanced distribution system with unique node numbering and branch. In this paper modification acquire the advantages over balanced distribution system in respect of memory. The developed algorithm applied over various practical systems [1].A solution technique to three phase practical distribution system. A solution technique is extended to get optimum location (reactive power) and reconfiguration (planning) for practical distribution system. The solution technique used by author is forward and backward propagation to find unknown node voltage and branch current [2].The author proposed the forward and backward sweep method for unbalanced distribution network. In this paper problem solution is obtained by considering transformer modeling and voltage regulation. The author has to apply 19 bus balanced system and to get valid and reliable mode [3].The author has to propose index vector method for optimal size and location of capacitor in unbalanced radial distribution system. In this paper includes unbalance as well as different loading in distribution system. This paper includes various parameters like losses, cost, size and allocation of capacitor in unbalanced distribution system [4].The author has to apply the reconfiguration and capacitor

placement in balanced and unbalanced radial distribution system by reducing the losses and maintain node voltage within permissible limits. An algorithm has been developed for multi-objective reconfiguration problem with fuzzy (capacitor placement) and hybrid Big-Bang-Big-crunch [5].A novel BFS (backward and forward sweep) load matrix approach to find the voltage using set theory for balanced/unbalanced radial as well weakly meshed distribution system[6].

II. PROBLEM FORMULATION

A two node circuit model is shown in Figure 1 for unbalanced three-phase radial distribution system [8]. We are working on radial distribution system which has high R/X ratio, so line charging admittance is neglected at the distribution voltage level. For this four-wire system, Carson’s equations lead to the development of an impedance matrix of 4×4 dimension. This matrix is used to calculate conductor voltage drop as shown below, using KCL, one may write:

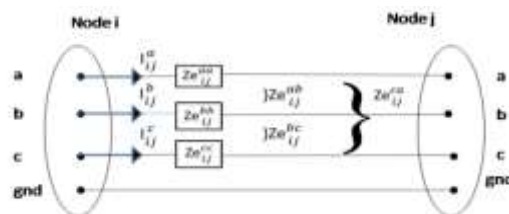

Figure 1: Unbalanced three-phase radial distribution system.

$$\begin{bmatrix} Vra \\ Vrb \\ Vrc \end{bmatrix} = \begin{bmatrix} Vsa \\ Vsb \\ Vsc \end{bmatrix} - \begin{bmatrix} Zaa & Zab & Zac \\ Zba & Zbb & Zbc \\ Zca & Zcb & Zcc \end{bmatrix} \begin{bmatrix} Ia \\ Ib \\ Ic \end{bmatrix}$$

..... (1)

$$Ia = [Sa / Vr], r = s, \text{for iteration} = 1 \text{ (2)}$$

$$Ib = [Sb / Vr], r = s, \text{for iteration} = 1 \text{ (3)}$$

$$Ic = [Sc / Vr], r = s, \text{for iteration} = 1 \text{ (4)}$$

Where,
s=sending, r=receiving

The total power at each node is given as:

$$S_{total} = \sum_{k=current\ power\ node}^{power\ beyond\ that\ node} S_k + \sum_{k=current\ power\ loss\ node}^{power\ loss\ beyond\ that\ node} S_k \text{ (5)}$$

$$SL_{loss} = [Vs_{loss} * I_{rs_{loss}} - Vr_{loss} * I_{rs_{loss}}], loss = a = b = c \text{ (6)}$$

III. ALGORITHM

The complete algorithm for load flow in unbalanced radial distribution system incorporating real power loss is given below. The total load supplied by sending node to the receiving node is explained by using an example. [8] Consider three phase 25-bus unbalanced radial distribution system is shown in figure2. The total power supplied by sending node 2 to receiving node 13 for phase a, b and c is as under:

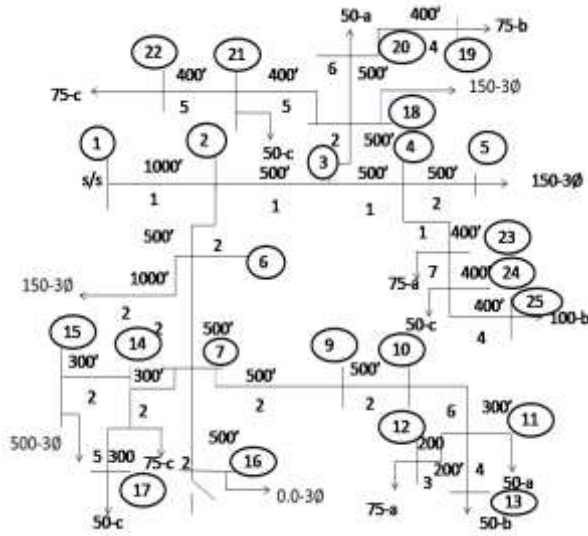

Figure2: 25-bus unbalanced radial distribution system

$$S^a_{2-13} = [\{S^a_{2-6} + S^a_{6-7} + S^a_{7-9} + S^a_{9-10} + S^a_{10-11} + S^a_{11-13}\} +$$

$$\{SL^a_{2-6} + SL^a_{6-7} + SL^a_{7-9} + SL^a_{9-10} + SL^a_{10-11} + SL^a_{11-13}\}] \text{ (7)}$$

$$S^b_{2-13} = [\{S^b_{2-6} + S^b_{6-7} + S^b_{7-9} + S^b_{9-10} + S^b_{10-11} + S^b_{11-13}\} + \{SL^b_{2-6} + SL^b_{6-7} + SL^b_{7-9} + SL^b_{9-10} + SL^b_{10-11} + SL^b_{11-13}\}] \text{ (8)}$$

$$S^c_{2-13} = [\{S^c_{2-6} + S^c_{6-7} + S^c_{7-9} + S^c_{9-10} + S^c_{10-11} + S^c_{11-13}\} + \{SL^c_{2-6} + SL^c_{6-7} + SL^c_{7-9} + SL^c_{9-10} + SL^c_{10-11} + SL^c_{11-13}\}] \text{ (9)}$$

1. Collect the input data like power at each node, impedance (self and mutual) and sending-receiving node for the given distribution network.
2. Determine the node power using forward/backward sweep method at each node of the given distribution network from equation (5)-(6). Set iteration count k=1: maxit.
3. Compute the branch current in each branch of distribution network from equation (2)-(4).
4. Determine node voltage using equation (1) for each node of the distribution network.
5. Calculate the losses using equation (6) at each bus and also find the total active as well reactive losses of the given distribution network.

6. The convergence criteria for the given distribution network is:

- i) $|\Delta V| = |V_{k+1} - V_k| \leq \alpha$ where α has minimum constant value.
- ii) $K \leq \text{maxit}$.

If above criteria is achieved then display the line flow, otherwise go to step 2.

IV. RESULT AND DISCUSSION

To test the algorithm of the proposed method, base voltage 4.16 kV unbalanced radial distribution system. The line data of the system is given in Appendix- A, power factor of load is considered as 0.8. The real power losses in KW for various phases are shown in figure 3:

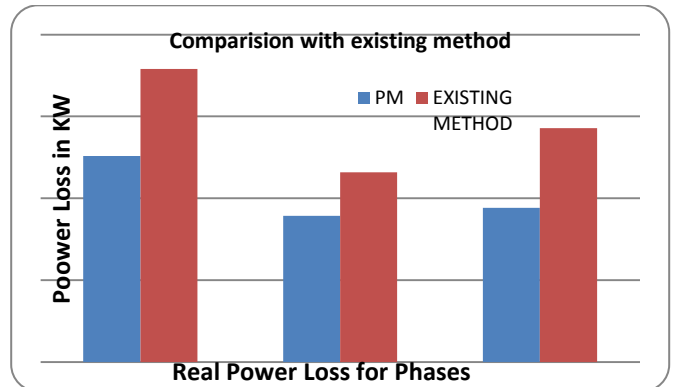

Figure 3: Comparison with existing method real power loss in KW for various phases

Table: 1 Real power loss in KW for three phase

Method	REAL LOSS(A)	REAL LOSS(B)	REAL LOSS(C)
Proposed	12.5836	8.92792	9.40728
Existing	17.91	11.586	14.286

The reactive power loss in KVAR for various phases is shown in figure 4:

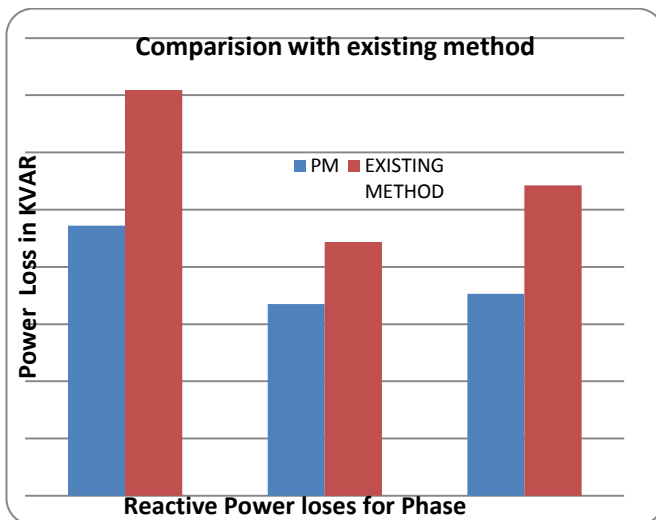

Figure 4: Comparison with existing method reactive power loss in KVAR for various phases

Table: 2 KVAR for three phases

Method	REACTI VE LOSS(A)	REACTI VE LOSS(B)	REACTI VE LOSS(C)
Proposed	9.4377	6.69594	7.05546
Existing	14.179	8.872	10.846

The voltage at each node for various phases is shown in figure 5:

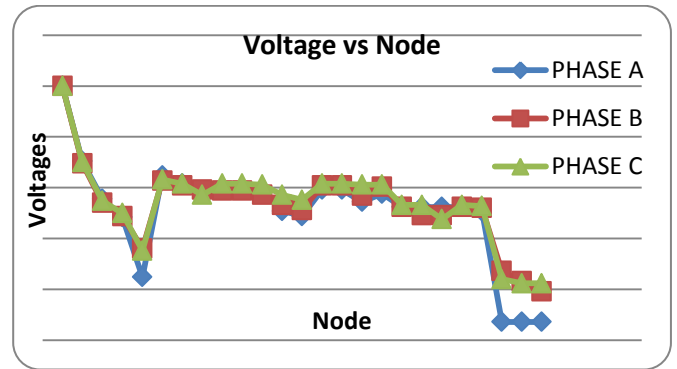

Figure 5: The voltage at each node for various phases

Table: 3 Voltage for 25-node in three phase.

NOD E	PHASE A	PHASE B	PHASE C	NOD E	PHASE A	PHASE B	PHASE C
1	1	1	1	14	0.9898	0.9902	0.9904
2	0.9926	0.9924	0.9925	15	0.9898	0.9902	0.9904
3	0.9889	0.9885	0.9888	16	0.9886	0.9892	0.9900
4	0.9871	0.9872	0.9875	17	0.9894	0.9900	0.9903
5	0.9812	0.9848	0.9838	18	0.9881	0.9881	0.9883
6	0.9912	0.9907	0.9908	19	0.9881	0.9873	0.9883
7	0.9904	0.9902	0.9904	20	0.9881	0.9873	0.9869
8	0.9897	0.9898	0.9893	21	0.9881	0.9881	0.9883
9	0.9899	0.9897	0.9904	22	0.9877	0.9881	0.9882
10	0.9899	0.9897	0.9904	23	0.9768	0.9818	0.9811
11	0.9898	0.9893	0.9903	24	0.9768	0.9808	0.9806
12	0.9877	0.9883	0.9893	25	0.9768	0.9798	0.9806
13	0.9872	0.9878	0.9888				

V. CONCLUSION

In this paper, a simple algorithm has been presented to solve unbalanced radial distribution system. The proposed method has good convergence property for any practical distribution system with practical R/X ratio. Computationally, this method is extremely efficient, as it solves simple algebraic recursive equations for voltage phasors.

VI. REFERENCES

[1] S. K. Goswami and S. K. Basu, "Direct solution of distribution systems," IEE Proc., Part C, vol. 188, no. 1, pp. 78-88, 1999.

[2] D. Thukaram, H. M W. Banda, and J. Jerome, "A robust three phase power flow algorithm for radial distribution systems," Journal of Electrical Power Systems Research, vol. 50, no. 3, pp. 227–236, June 1999.

[3] Puthireddy Umapathi Reddy1 , Sirigiri Sivanagaraju2 , Prabandhamkam Sangameswararaju3, "power flow analysis of three phase unbalanced radial distribution system," International Journal of Advances in Engineering & Technology, Vol. 3, Issue 1, pp. 514-524, March 2012.

[4] V.V.S.N.Murtya , Ashwani Kumarb, "Capacitor Allocation in Unbalanced Distribution System under Unbalances and Loading Conditions," 4th International Conference on Advances in Energy Research 2013, ICAER 2013, Energy Procedia 54 (2014) 47 – 74.

[5] Mostafa Sedighzadeh *, Reza Bakhtiary," Optimal multi-objective reconfiguration and capacitor placement of distribution systems with the Hybrid Big Bang–Big Crunch algorithm in the fuzzy framework," Ain Shams Engineering Journal (2016) 7, 113–129

[6] Ujjwal Ghatak and V. Mukherjee " A fast and efficient load flo technique for unbbalanced distribution system', electrical power and energy system 84 (2017) 99-110.

[7] S.Frank, J. Sexauer, and S. Mohagheghi, "Temperature Dependent Power Flow," IEEE Trans. Power Syst., vol. 28, pp. 4007-4018, Oct. 2013

[8] R. Ranjan, B. Venkatesh, A. Chaturvedi and D. Das, "Power Flow Solution of Three-Phase Unbalanced Radial Distribution Network," Electric Power Components and Systems, 421-433, 24th June 2010.

Appendix -A:

Sending	Receiving	Sa	Sb	Sr	Sa	Zab	Zbr	Zar	Zbr	Zar
1	2	0	0	0	0.36867+*i.48523	0.37548+*i.67146	0.37720+*i.67017	0.00497+*i.0.12545	0.00828+*i.0.20773	0.01545+*i.0.12579
2	3	0	0	0	0.36867+*i.48523	0.37548+*i.67146	0.37720+*i.67017	0.00497+*i.0.12545	0.00828+*i.0.20773	0.01545+*i.0.12579
3	4	0	0	0	0.36867+*i.48523	0.37548+*i.67146	0.37720+*i.67017	0.00497+*i.0.12545	0.00828+*i.0.20773	0.01545+*i.0.12579
4	5	50	50	50	0.97748+*i.0.87166	0.98439+*i.0.86543	0.01533+*i.1.2638	0.00674+*i.0.18980	0.00856+*i.0.21754	0.98032+*i.0.86477
5	6	0	0	0	0.97748+*i.0.87166	0.98439+*i.0.86543	0.01533+*i.1.2638	0.00674+*i.0.18980	0.00856+*i.0.21754	0.98032+*i.0.86477
6	7	0	0	0	0.97748+*i.0.87166	0.98439+*i.0.86543	0.01533+*i.1.2638	0.00674+*i.0.18980	0.00856+*i.0.21754	0.98032+*i.0.86477
7	8	50	50	50	0.97748+*i.0.87166	0.98439+*i.0.86543	0.01533+*i.1.2638	0.00674+*i.0.18980	0.00856+*i.0.21754	0.98032+*i.0.86477
8	9	75	0	0	0.97748+*i.0.87166	0.98439+*i.0.86543	0.01533+*i.1.2638	0.00674+*i.0.18980	0.00856+*i.0.21754	0.98032+*i.0.86477
9	10	0	50	0	0.97748+*i.0.87166	0.98439+*i.0.86543	0.01533+*i.1.2638	0.00674+*i.0.18980	0.00856+*i.0.21754	0.98032+*i.0.86477
10	11	50	0	0	0.97748+*i.0.87166	0.98439+*i.0.86543	0.01533+*i.1.2638	0.00674+*i.0.18980	0.00856+*i.0.21754	0.98032+*i.0.86477
11	12	75	0	0	0.9280+*i.1.41939	0	0	0	0	0
12	13	0	50	0	0.9280+*i.1.41939	0	0	0	0	0
13	14	0	0	75	0.97748+*i.0.87166	0.98439+*i.0.86543	0.01533+*i.1.2638	0.00674+*i.0.18980	0.00856+*i.0.21754	0.98032+*i.0.86477
14	15	100.7	100.7	0	0.97748+*i.0.87166	0.98439+*i.0.86543	0.01533+*i.1.2638	0.00674+*i.0.18980	0.00856+*i.0.21754	0.98032+*i.0.86477
15	16	0	0	0	0.97748+*i.0.87166	0.98439+*i.0.86543	0.01533+*i.1.2638	0.00674+*i.0.18980	0.00856+*i.0.21754	0.98032+*i.0.86477
16	17	0	0	50	0	0	0.9280+*i.1.41939	0	0	0
17	18	50	50	50	0.97748+*i.0.87166	0.98439+*i.0.86543	0.01533+*i.1.2638	0.00674+*i.0.18980	0.00856+*i.0.21754	0.98032+*i.0.86477
18	19	50	0	0	0.97748+*i.0.87166	0.98439+*i.0.86543	0.01533+*i.1.2638	0.00674+*i.0.18980	0.00856+*i.0.21754	0.98032+*i.0.86477
19	20	0	75	0	0.9280+*i.1.41939	0	0	0	0	0
20	21	0	0	50	0	0	0.9280+*i.1.41939	0	0	0
21	22	0	0	75	0	0	0.9280+*i.1.41939	0	0	0
22	23	75	0	0	0.97748+*i.0.87166	0.98439+*i.0.86543	0.01533+*i.1.2638	0.00674+*i.0.18980	0.00856+*i.0.21754	0.98032+*i.0.86477
23	24	0	0	50	0.97748+*i.0.87166	0.98439+*i.0.86543	0.01533+*i.1.2638	0.00674+*i.0.18980	0.00856+*i.0.21754	0.98032+*i.0.86477
24	25	0	100	0	0.9280+*i.1.41939	0	0	0	0	0