

# A Smart Switch to Connect and Disconnect Electrical Devices At Home by Using Internet

A. Sukanya Rani<sup>1\*</sup>, S. Umamaheshwar<sup>2</sup>

<sup>1\*</sup>Department of ECE, S R Engineering College, Warangal, India

<sup>2</sup>Department of ECE, S R Engineering College, Warangal, India

\*Corresponding Author: [deviswe@gmail.com](mailto:deviswe@gmail.com)

Available online at: [www.ijcseonline.org](http://www.ijcseonline.org)

Received: 26/Dec/2017, Revised: 30/Dec/2017, Accepted: 20/Feb/2018, Published: 28/Feb/2018

**Abstract**— This project presents the development of a firmware for a Smart Switch, which can control the on-off of any electrical device at home by using internet. The Smart Switch is connected to internet via Wi-Fi, through a computer, smartphone, tablet or any device with internet access. In order to perform this connection it is necessary to write the IP pre-programmed into the Smart Switch in a web browser (Internet Explorer, Chrome, Firefox, etc.) with the purpose to load the Smart Switch server, which will open a configuration page to write the data of the user's network. Then, the user will select in automatic mode the network, the security type, and the user must have written a passphrase. Once these information is uploaded and saved, it is necessary to restart the Smart Switch in order to get access to internet, from which the user can control the Smart Switch simply sending a number one or a number zero to switch the electrical device, this process is done in principle via the internet.

**Keywords**— Home automation, internet of things, embeddedswitch

## I. INTRODUCTION

Home automation has been a feature of science fiction writing for many years, but has only become practical since the early 20th Century following the widespread introduction of electricity into the home, and the rapid advancement of information technology. Home automation refers to the application of computer and information technology for control of home appliances easily. It is a automation of the home, housework or household activity. Home automation may include centralized control of Light, Appliances, Temperature and other systems, to provide improved convenience. Comfort, energy efficiency and security. Home automation for the elderly and disabled can provide increased quality of life for persons who might otherwise require caregivers or institutional care. The popularity of home automation has been increasing greatly in recent years due to much higher affordability and simplicity through Smartphone and tablet connectivity. The concept of the "Internet of Things" has tied in closely with the popularization of home automation. Through the integration of information technologies with the home environment, systems and appliances are able to communicate in an integrated manner which results in convenience, energy efficiency, and safety benefits.

As we are using **Arduino Uno**. It is a popular open-source single-board microcontroller, descendant of the open-source Wiring platform, designed to make the

process of using electronics in multidisciplinary projects more accessible. The hardware consists of a simple open hardware design for the Arduino board with an Atmel AVR processor and on-board input/output support. The software consists of a standard programming language compiler and the boot loader that runs on the board.

Arduino hardware is programmed using a Wiring-based language (syntax and libraries), similar to C++ with some slight simplifications and modifications, and a Processing-based integrated development environment.

## II. LITERATURE SURVEY

In this paper they have developed an IoT based home automation system which makes use of a micro-controller and a java based android application. The micro-controller used is ATmega328. They have also made use of a GSM module which helps the system to be used remotely. They presents a low cost and flexible home control and monitoring system using an embedded micro-web server, with IP connectivity for accessing and controlling devices and appliances remotely using Android based Smart phone app. The proposed system does not require a dedicated server PC with respect to similar systems and offers a novel communication protocol to monitor and control the home environment with more than just the switching functionality. To demonstrate the feasibility and effectiveness of this system, devices such as light switches,

power plug, temperature sensor and current sensor have been integrated with the proposed home control system.

### 1. IR Based home automation system:

In this project, Arduino is used for controlling whole the process. We send some commands to the controlling system by using IR TV/DVD/MP3 remote for controlling AC home appliances. After receiving signal from IR remote, Arduino sends related signal to relays which are responsible for switching ON or OFF of the home appliances through a relay driver. By using IR there is a drawback in this system it is a line on sight communication.

### 2. RF Based home automation system:

To develop a home automation system with an RF controlled remote, houses are also getting smarter. As technology is advancing so houses are also getting smarter. Modern houses are gradually shifting from conventional switches to a centralized control system, involving radio frequency controlled switches. Using RF module this system is Omnidirectional. There is a drawback as this system is only for limited distance

### 3. Bluetooth based home automation system using cell phones:

In Bluetooth based home automation system the home appliances are connected to the Arduino BT board at input output ports using relay. The program of Arduino BT board is based on high level interactive C language of microcontrollers, the connection is made via Bluetooth. The password protection is provided so only authorized user is allowed to access the appliances. The Bluetooth connection is established between Arduino BT board and phone for wireless communication. In this system the python script is used and it can install on any of the Symbian OS environment, it is portable. One circuit is designed and implemented for receiving the feedback from the phone, which indicate the status of the device. This system is also for limited distance.

### 4. Zigbee based home automation system using cell phones:

To monitor and control the home appliances the system is designed and implemented using Zigbee. The device performance is record and store by network coordinators. For this the Wi-Fi network is used, which uses the four switch port standard wireless ADSL modern router. The network SSID and security Wi-Fi parameter are preconfigured. The message for security purpose first

process by the virtual home algorithm and when it is declared safe it is re-encrypted and forward to the real network device of the home. Over Zigbee network, Zigbee controller sent messages to the end. The safety and security of all messages that are received by the virtual home algorithm. Operating range is more than Bluetooth. But the system does not allow remote monitoring and controlling of appliances.

### 5. GSM based home automation system using cell phones:

Because of the mobile phone and GSM technology, the GSM based home automation is lure to research. The SMS based home automation, GPRS based home automation and dual tone multi frequency (DTMF) based home automation, these options we considered mainly for communication in GSM. Different AT commands are sent to the Home Mobile for controlling different appliances. The drawback of this system is that a Graphical User Interface (GUI) is not provided to the user. Different AT commands have to be remembered by the users to control the connected devices. Also, the system supports Java enabled mobile phones. The system thus becomes less functional as now-a-days the use of Java enables phones are reducing and the use of Android phones are increasing tremendously.

## III. METHODOLOGY

In this paper we presenting presenting a design and prototype implementation of new home automation system that uses WiFi technology as a network infrastructure connecting its parts. Their system consists of two main components; the first part is the server (web server), which presents system core that manages, controls, and monitors users' home. Users and system administrator can locally (LAN) or remotely (internets) manage and control system code. Second part is hardware interface module, which provides appropriate interface to sensors and actuator of home automation system. Unlike most of available home automation system in the market the proposed system is scalable that one server can manage many hardware interface modules as long as it exists on Wi-Fi network coverage. System supports a wide range of home automation devices like power management components, and security components. The proposed system is better from the scalability and flexibility point of view than the commercially available home automation systems [3].

The system has two parts, namely; hardware and software. The hardware system consists of arduino uno board, arduino wi-fi shield, sensors and home appliances. The software system consists of a java based android application also arduino language is used to configure the arduino uno board. In this system, the components used are arduino uno board, arduino wi-fi shield, relays. These hardware components are used in order to control the home appliances. Arduino uno board will help to develop an interface between the hardware and the software application. This system also consists of a software

application which is developed using android. The arduino wi-fi shield will help in transmitting and receiving the input given by the user [2].

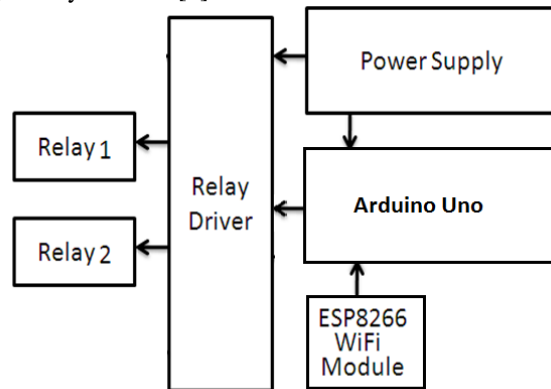

Figure 1 Block Diagram Design

#### Cloud Based home automation system:

Home Automation using cloud based system focuses on design and implementation of home gateway to collect data about data from home appliances and then send to the cloud-based data server to get store on Hadoop Distributed File System, it is process using MapReduce and use to implement a monitoring tasks to Remote user Presently home Automation System is persistently developing its resilience by assimilating the current characteristics which gratify the rising interest of the people. This paper presents the design and development of home automation system that use the cloud computing as service. The current system consists of three important units: the first part is cloud server, handle and controls the data and information of client and users and the status of devices. The hardware interface module is the second part which implement the relevant connection to the actuators and sensing devices which give the physical service. Last part is Home Server, which construct the hardware device and gives the user interface. This paper focus to build the web services using cloud which is need for security and storage and availability of the data. The current system is cost efficient, reliable and comfortable which also gives a secured home automation system for entire family.

The system is made up of various client modules for various platforms.

1. Cloud server Cloud Server is a central server aims on implementing services to the other sub modules. Central server serves as the data respiratory system and brain It implementsthree connections to the three sub modules vizhome system, web configuration tool and mobile. The server evaluatesthe data it takes from the house, send current status to the mobile device and vice versa. A database is managing by the server and it is status gets updated as per the changes done at home end.

2. Embedded Program for Hardware Circuit Microcontroller, and.
3. Internet Client for any desktop or mobile phones

The proposed Home Automation System enhances mobility and supports monitoring and control of devices from any remote location. Being a simple and user friendly application it serves as an application of great help to the old aged or physically disabled people. Thus, the Internet of Things based Home Automation System is better than all traditional existing Home Automation Systems.

#### MQTT

Message Queuing Telemetry Transport (MQTT) is aa ISO standard protocol which works over the top of TCP/IP. MQTT is used to connect remote locations or micro code servers for controlling embedded devices over IOT. This service comes handy when the bandwidth is very low and command has to be passed with few bytes of data. a message broker is required for public-subscribe messaging.

MQTT is a variation of the main protocol aimed at embedded devices on non-TCP/IP networks, such as ZigBee.It's basically a lightweight connectivity protocol between machine to machine for internet of things. A microcontroller running a micro code footprint serves as remote server and can handle a number of devices and can also be controlled remotely, which opens a gate for globalization and control of the any IOT based control system or Embedded system. This ability of MQTT is inducted by many industry operators in healthcare and productions platforms. MQTT version 3.1 has aOASIS security standard which works on SSL.

#### ARDUINO UNO

Arduino/Genuino Uno is a microcontroller board based on the ATmega328P (datasheet). It has 14 digital input/output pins (of which 6 can be used as PWM outputs), 6 analog inputs, a 16 MHz quartz crystal, a USB connection, a power jack, an ICSP header and a reset button. It contains everything needed to support the microcontroller; simply connect it to a computer with a USB cable or power it with a AC-to-DC adapter or battery to get started.. You can tinker with your UNO without worrying too much about doing something wrong, worst case scenario you can replace the chip for a few dollars and start over again [2].

"Uno" means one in Italian and was chosen to mark the release of Arduino Software (IDE) 1.0. The Uno board and version 1.0 of Arduino Software (IDE) were the reference versions of Arduino, now evolved to newer releases. The Uno board is the first in a series of USB Arduino boards, and the reference model for the Arduino platform; for an extensive list of current, past or outdated boards see the Arduino index of boards.



Fig -2: ARDUINO UNO BOARD

### ARDUINO WI-FI SHIELD

ESP8266 is a great thing for starting to Wifi And IOT. It is also cheap and be used for making cool projects connected to the Internet. Learn how to make a simple IOT Project with it. The ESP8266 WiFi Module is a self contained SOC with integrated TCP/IP protocol stack that can give any microcontroller access to your WiFi network.

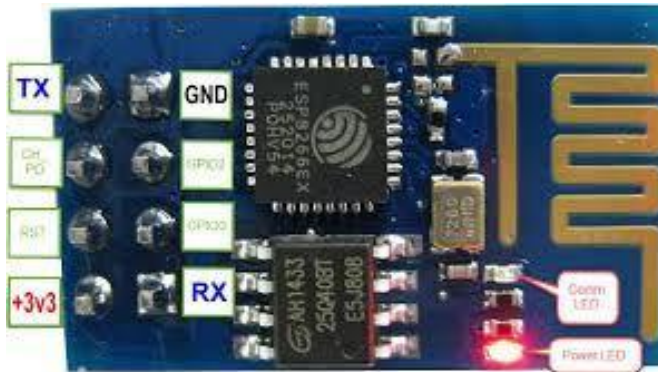

Fig.3 ARDUINO WI-FI SHIELD

### WHY ARDUINO?

- Arduino is open source prototyping platform.
- Arduino based language is available for developing inputs and interacting with other softwares.
- Supported in all operating systems.
- Main aspect of it is less expensive than other prototyping systems available.
- You can get Arduino board with LOTS of different I/O and other interface configurations.
- The Pi is pretty much what it is and has a lot less time in the field.
- Pi - for \$35 you get video, audio, Ethernet , and USB.
- That will cost you 2X that to get the same on top of an Arduino UNO.
- The Arduino UNO runs comfortably on just a few milliamps
- The Pi needs more like 700mA whereas arduino

requires less power.

### IV. PROPOSED SYSTEM RESULTS

The main aim of this project is to control the electrical appliances from anywhere in the world by using the web server and using the GPRS module. Here in this project we are controlling both the AC and DC loads.



Results

Fig.4



Fig.5

### V. CONCLUSION AND FUTURESCOPE

A Smart Home system integrates electrical devices in a house with each other. The techniques which are going to use in home automation include those in building automation as well as the control of domestic activities, such as TV, fan, electric tubes, refrigerator and washing machine. After studying and understanding literature survey and other existing works, we proposed a Novel technique that will gives us better understanding of the Environmental conditions in home. Our system not only just monitors environmental conditions but it acts according to inhabitant requirement. In this paper we are planning to eliminate most of the human interaction by providing intelligent system. Development of such Smart Home achieve by using Internet of Things technologies. By using these system we can actually manage to make low cost, flexible smart homes to adjust its environmental conditions and resolve its errors with energy saving.

### References

- [1] Ajah, G, David, N, Abioye, A, Web Based Security System, Sch. J. Eng. Tech, 1(3):112-116, 2013.
- [2] Mahmood, S M, Abdulsattar, M, Firas, A Y; Home Automation Management with WLAN (802.11g) and RF Remote Control, Raf. J. of Comp. & Math's, 6(1), 2009.
- [3] Aru O E ,Ihekweaba G, Opara F K, Design Exploration of a Microcontroller Based RF Remote Control 13amps Wall Socket, IOSRJCE, 11(1), 56-60, 2013.
- [4] David, N, Design of an Internet Based Security System, NIJOTECH, 29(2) 118-129, 2010.
- [5] Diao, M F, Mahmood, B M, Data Acquisition of Greenhouse Using Arduino, Journal of Babylon University/Pure and Applied Sciences/ No.(7)/ Vol.(22), 1908-1916, 2014.
- [6] Asif, O, Hossain, B, Hasan M, Rahman, T, Chowdhury, M, Fire-Detectors Review and Design of an Automated, Quick Responsive Fire-Alarm, 2014