

# Comparison between Baud Rates for Serial Video Data Transmission over Zigbee in Wireless Sensor Network

<sup>1\*</sup>Mrunal Khedkar, <sup>2</sup>G.M. Asutkar

<sup>1,2</sup>Electronics and Comm. Engg. Dept, Priyadarshini Institute of Engineering and Technology, Nagpur, Maharashtra, India

\*Corresponding Author: [mrunal18kh@gmail.com](mailto:mrunal18kh@gmail.com)

Available online at: [www.ijcseonline.org](http://www.ijcseonline.org)

Accepted: 18/Jan/2019, Published: 31/Jan/2019

**Abstract**— For transmitting real time information (over the standalone network), video wireless sensor networks are becoming more popular. As the video data is inherently very large in size, it requires more memory, greater processing speed and larger bandwidth for its transmission. In this paper, zigbee is used for video transmission, as it economical and consumes less power. The video is initially compressed using discrete cosine transform (DCT) based compression technique and then transmitted over zigbee using two different baud rates. The same video is transmitted number of times at two different baud rates, which helps in comparing and getting more accurate values of various parameters for video transmission at two different baud rates. Comparison is carried out by calculating average values of image parameters, transmission time, reception time, frame loss and frame delay independently. Finally reliable and efficient baud rate is found out for video data transmission over zigbee network.

**Keywords**—Wireless Sensor Network (WSN); Video Wireless Sensor network (VWSN); Zigbee; baud rate, Peak Signal to Noise Ratio (PSNR), Mean Square Error (MSE), Structural Similarity Index (SSI), Compression Ratio (CR)

## I INTRODUCTION

Wireless sensor networks consist of large number of nodes spread over certain geographical area, to monitor various parameters. WSN is a standalone and resource constrained network, as each node is battery operated. In VWSN each sensor node consists of camera, memory unit, processing unit, trans-receiver unit and battery. Transmission of video over the network facilitates exact real time information exchange. Video data transmission takes place between different nodes or between the nodes and base station depending upon the network architecture. The transmission of video over the network is a challenging task due to resource constraints such as limited battery life, low data rate, low power, limited memory and lower processing speed. Video data is inherently huge in size and it needs to be processed at each node before transmission. In this paper, zigbee protocol is used for serial transmission of video data. Zigbee is a secure, reliable, low cost, low speed, low power network protocol based on IEEE 802.15.4 standard. It is suitable for applications with infrequent data transmission needs. Zigbee supports different topologies like star network, full mesh network and hybrid network. Types of nodes under Zigbee are coordinator, router and end devices. Zigbee specification supports at the most one coordinator, multiple routers, and multiple end devices within a single network. Operating frequency is 2.4GHz and maximum data rate is 250kbps. It has serial data rate from 1200bps up to 1Mbps. It covers a range up to 40mts and line of sight range up to 120mts.

This paper considers two different baud rates for video data transmission over zigbee. The video is transmitted several times over each baud rate in order to get more accurate values of all parameters. Finally two baud rates are compared on the basis of different image parameters like PSNR, MSE, SSI and communication parameters as transmission time, reception time, frame loss and frame delay. MATLAB is applied for simulation purpose and X-CTU software is used for setting up hardware parameters of Zigbee node.

Organisation of the paper is as follows. Section II contains related work, which discusses various research works carried out in this area. Section III explains lossless image compression; in this DCT based lossless compression technique is discussed. Section IV consists of image parameters where the formulae for PSNR, MSE, SSI and CR are discussed. Section V discusses methodology for the research work. Section VI elaborates hardware setup in which zigbee trans-receiver modules are discussed. Section VII gives results in which various parameter values are listed out. Conclusion of the research work is presented in Section VIII.

## II RELATED WORK

Maung, S *et.al*; [1] discussed the comparative analysis of global throughput, MAC delay and data dropped rate as the parameters of QoS for simulation based office network. Riverbed Modeler version 17.5 is used for designing and

implementation of ZigBee network. In the paper by Ievgeniia Kuzminykh *et.al*; [2], configuration and testing of ZigBee modules was performed by using XCTU software. Indoor distance of 25mts and outdoor distance of 60mts is recommended range for data transmission over zigbee. Dan Tao *et.al*:[3] paper implements a practical image sensor node for image data's gathering, processing and transmission with low-power sleeping mechanism. An efficient zigbee based retransmission mechanism is also proposed to improve the transmission reliability. Relationship between packet loss rate and retransmission time is shown. Chia-Hsin Cheng *et.al* [4] paper improves the packet delivery ratio by applying multi channel technology. An interference avoidance method to improve conditions for the coexistence of ZigBee and WLAN is studied and practically implemented to evaluate the resulting performance. In the paper by M. Masurkar *et.al*,[5], different network topologies are compared and the computation of transmission power, rate and link schedule for life time maximization of energy constrained wireless sensor network is also done. P D Joshi, G M Asutkar [6] paper focuses the lifetime-aware battery allocation problem for sensor networks with heterogeneous power distributions. Lossless Sleep Doze Coordination (LSDC) protocol is proposed to improve the life span of WSN with heterogeneous spatial power consumption distributions. Xiaoxia Ren; Zhigang Yang [7] have discussed key research issues on video sensor network, specifically camera coverage problem, network architecture and low-power video data processing and communication. The enabling approaches for these issues are also identified.

From the research carried out in VWSN area; it is observed that most of the researchers have focused on optimising and improving network life time. For achieving it, the areas like

battery life optimization, various routing techniques and network topologies are focused. However the area of comparison between different baud rates based on average values of various image and communication parameters remains quite unexplored. Thus this paper focuses on effect on various parameters at different baud rates.

### III LOSSLESS VIDEO COMPRESSION

Compression is the first stage for processing of video data. The video is split into frames and the compression is applied on each frame. The compression can be done in two ways: lossy and lossless. In lossless data compression algorithms [8], the compressed data is perfect reconstruction of original data. Whereas in lossy compression technique, compressed data is only the approximation of original data. The reduction in file size is more in lossy compression as compared to lossless compression but at the cost of data loss. DCT has excellent energy compaction properties and thus it is selected as a standard for JPEG image compression.

Initially the video is obtained and which is converted into series of frames. After this lossless DCT transform using 8X8 block size applied on each of these frames in order to compress it. Due to lossless video compression, the quality of video data is maintained as it is and the size of data is drastically reduced, which makes it suitable for transmission over the network. Figure 1 shows MATLAB output of one frame after applying DCT compression technique. It displays the original frame of size 18.228 Kb and compressed frame of size 9.701 Kb. Thus compression ratio (CR) of 47.28% is obtained for this image frame. The CR for different image frames is listed out in Table 1 and Table 3.

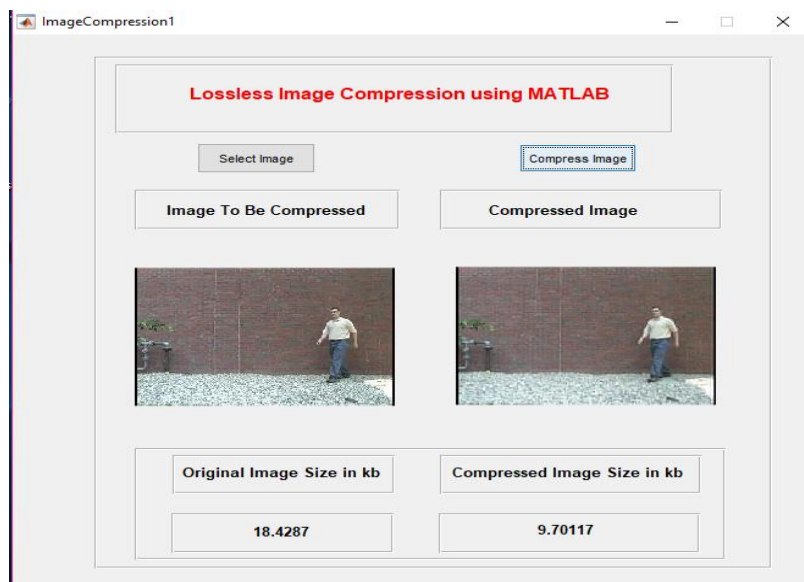

Figure 1: Original image frame and Compressed image frame using matlab

#### IV IMAGE PARAMETERS

Various image parameters [9] are evaluated like Mean Square Error (MSE), Peak Signal to Noise Ratio (PSNR) and Structural Similarity Index (SSI). These parameters are evaluated separately at two different baud rates and the results are shown in Table 1 and Table 3. Image parameters or the image quality metrics measure the distortion in a received image at receiver as compared to the reference image at the transmitter.

These parameters are as follows:

##### A) Mean Square Error (MSE):

It is the cumulative squared error between the original image and the received image. MSE is given as:

$$MSE = \frac{1}{MN} \sum_{m=1}^M \sum_{n=1}^N \{O(i,j) - R(i,j)\}^2 \quad (1)$$

Where,  $O(i,j)$  is the original image,  $R(i,j)$  is the received image and dimension of image is  $M \times N$

##### B) Peak Signal to Noise Ratio (PSNR):

In the present scenario, signal represents original image before transmission and the noise represents the compression and transmission losses. Thus PSNR represents the overall quality of the received image.

$$PSNR = 10 \log_{10} \frac{MAX_O^2}{MSE} \quad (2)$$

Where,  $MAX_O$  is the maximum value of pixels in the given image, each pixel represents 8 bits hence  $MAX_O = 2^n - 1 = 255$ ,  $n$  is bits per pixel.

##### C) Structural Similarity Index (SSI):

MSE and PSNR both measure the absolute error between original image and received image; whereas SSI measures the degradation in structural information of received image as compared to original image. Thus SSI measures the similarity between two images. The value of SSI lies between 0 and 1, if the two images are exactly same then value is 1. Lower the value of SSI, similarity is lesser between the two images.

$$SSI(x, y) = \frac{(2\mu_x\mu_y + c_1)(2\sigma_{xy} + c_2)}{(\mu_x^2 + \mu_y^2 + c_1)(\sigma_x^2 + \sigma_y^2 + c_2)} \quad (3)$$

Where  $x$  is original image of size  $N \times N$  and  $y$  is received image of size  $N \times N$ .  $\mu_x$  and  $\mu_y$  is the average value of  $x$  and  $y$  respectively.  $\sigma_x^2$  and  $\sigma_y^2$  is the variance of image  $x$  and  $y$  respectively and  $\sigma_{xy}$  is the covariance of  $x$  and  $y$ .

##### D) Compression ratio:

Compression ratio is the ratio of compressed image size to original image size. Percentage of compression ratio is given by:

$$CR(\%) = [(\text{Original size} - \text{Compressed size}) / (\text{Original size})] * 100 \quad (4)$$

#### V METHODOLOGY

Sample video is taken as input. The video is initially converted into frames and lossless compression is applied to each frame. Each frame is a RGB colour image. Subsequently, each frame matrix which is of the size  $360 \times 240$  is resized into  $64 \times 64$ . The baud rate for zigbee module is set on both transmitter and receiver side. Two baud rates 19200 bps and 38400 bps are compared. During transmission of video; initially the baud rate is set. Then image matrix of size  $64 \times 64$  is converted into serial form and transmitted serially over zigbee. At the receiver, serial data is received and reconstructed back into the matrix. This whole process is completed in one run of video transmission. Likewise in order to get more appropriate values of transmission time, reception time, frame loss and frame delay, same video is sent multiple times over the network. Various image parameters are then calculated to check the quality of reconstructed image as compared to original image. Frame delay is also calculated which is defined as difference between the time when the first packet of it is sent by sender and the time when last packet of the frame is received by receiver. Frame loss indicates whether all the frames that were transmitted by the transmitter were received at receiver or not. If all the frames are not received then frame loss is present, and if all frames are received then frame loss is absent.

Algorithm:

- Step 1: Take input video
- Step 2: Convert Video to frames
- Step 3: Apply lossless compression on each frame
- Step 4: Resize each frame into  $64 \times 64$
- Step 5: Convert pixel matrix of each frame into serial data
- Step 6: Set the baud rate of Tx and Rx unit
- Step 7: Open port at transmitter
- Step 8: Fix output buffer size for serial data transmission
- Step 9: Output serial data
- Step 10: Fix input and output buffer size at receiver
- Step 11: Open port at receiver
- Step 12: Receive serial data
- Step 13: Separate serial data into 3 parts for reconstruction of RGB frames
- Step 14: Reshape into matrix
- Step 15: Display O/P at receiver
- Step 16: Calculate all the parameters
- Step 17: Repeat the above steps for next run

#### VI HARDWARE SETUP

The video transmission takes place practically using two XBee-S2C modules as shown in Fig.2. One of them is configured as transmitter and the other one as receiver as shown in Fig.3. Each of these Xbee modules is mounted on CB-1 peripheral board and it is directly connected to PC, by

RS-232. Power supply for the modules is taken from PC once it is connected. X-CTU software is used to setup the hardware parameters. This X-CTU tool provides a GUI and terminal interface to configure the modules as well as a built in tool to test the Xbee range and reliability of packet

transmission. Various baud rates for both the modules are also setup using this tool. After the actual transmission of video, the transmission time, reception time, frame loss and frame delay are calculated.

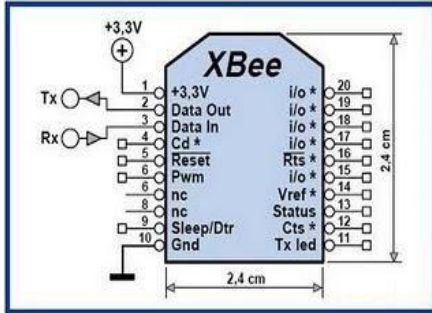

Figure 2: Pin diagram of Zigbee module



Figure 3: Picture of Zigbee Tx and Rx

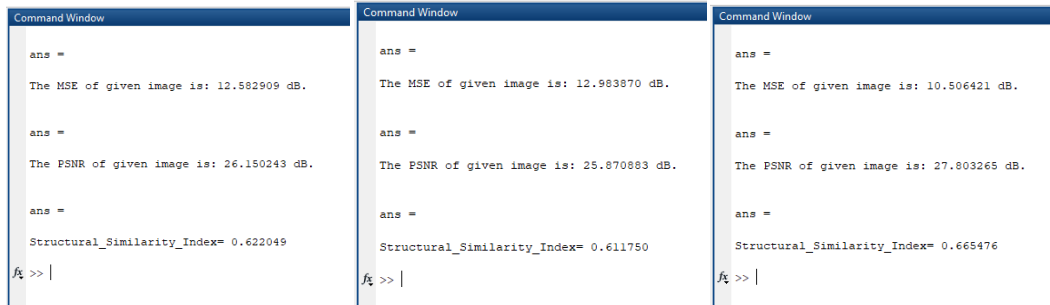

Figure 4 (a,b,c): Matlab simulation output for image parameters: MSE, PSNR and SSI

**VII RESULTS**

*a) Final results at baud rate 38400*

Initially the video is converted into frames and each frame is compressed. After compression the size of frame matrix is 360X240. Each of these compressed frames is resized into 64X64 and then transmitted serially over zigbee at 38400bps baud rate. Figure 5 shows the transmitted 64X64 image

frames. When the data is received at receiver, these frames are reconstructed back. Figure 6 shows the received frames. After getting both transmitted and received frames, image parameters are calculated in MATLAB as shown in Figure 4. Table 1 shows the detailed list of image parameters namely MSE, PSNR, SSI and CR for all the transmitted and received frames at 38400 bps.

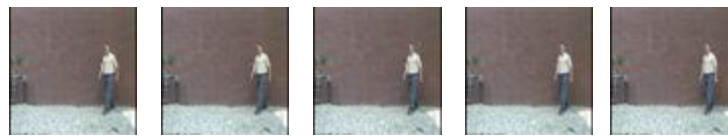

Figure 5 (a-e): Transmitted image frames (64X64) at 38400 baud rate

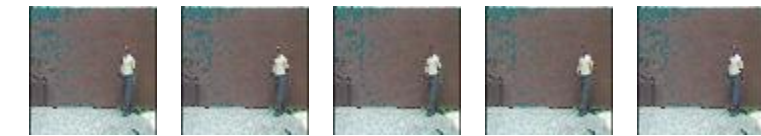

Figure 6 (a-e): received image frames (64 X 64) at 38400 baud rate

Table 1: Image parameters at 38400 baud rate

Frame No.	Original frame size (KB)	Compressed frame size (KB)	CR (%)	MSE	PSNR	SSI
Frame 1	18.4	9.70	47.282	12.911656	25.917240	0.618791
Frame 2	18.7	9.70	48.128	12.981676	25.871961	0.617084
Frame 3	18.6	9.65	48.118	12.983870	25.870883	0.611750
Frame 4	18.7	9.64	48.449	12.838988	25.968139	0.611221
Frame 5	18.8	9.63	48.776	13.001938	25.858675	0.613323
Frame 6	18.8	9.61	48.882	10.506421	27.803265	0.665476
Frame 7	18.9	9.61	49.153	13.001149	25.860378	0.611721
Frame 8	18.3	9.69	47.049	13.080974	25.814170	0.605028
Frame 9	18.5	9.64	47.891	12.980698	25.878613	0.599133
Frame 10	18.6	9.65	48.118	12.582909	26.150243	0.622049

The communication parameters like transmission time, reception time, frame delay and frame loss are evaluated. For getting better and accurate results same video is transmitted multiple times at 38400 bps baud rate. Table 2 shows the average transmission time (Avg. TX-time), average reception time (Avg. RX-time), average frame delay and presence or

absence of frame loss during each run. Average value of transmission time is approximately 3.071 sec, reception time is 3.50 sec and average frame delay is 0.22 sec for all 10 runs. All the frames that are transmitted are not received after every run, thus frame loss is present in some –viz- RUN 1, 3,7,9,10,15.

Table 2: Average Tx-Rx time, frame loss and frame delay at 38400

RUN no.	Avg. TX Time (sec)	Avg. RX Time (sec)	Avg. Frame Delay (sec)	Frame Loss
RUN 1	3.07155	5.98572	2.91417	Yes
RUN 2	3.07315	3.32045	0.2473	No
RUN 3	3.07241	3.98551	0.9131	Yes
RUN 4	3.0698	3.29634	0.22654	No
RUN 5	3.0717	3.30397	0.23227	No
RUN 6	3.07046	3.3035	0.23304	No
RUN 7	3.07116	3.96577	0.89461	Yes
RUN 8	3.07131	3.29287	0.22156	No
RUN 9	3.0701	3.97704	0.90694	Yes
RUN 10	3.07022	3.97704	0.90682	Yes
RUN 11	3.07094	3.35658	0.28564	No
RUN 12	3.07053	3.30974	0.23921	No
RUN 13	3.07017	3.4127	0.34253	No
RUN 14	3.07068	3.32723	0.25655	No
RUN 15	3.071	3.96944	0.89844	Yes

#### b) Final results at baud rate 19200 bps

Figure 7 (a,b,c,d,e) shows the serially transmitted video frames from zigbee transmitter having matrix size 64X64 at

19200bps. Figure 8 (a,b,c,d,e) shows the serially received and reconstructed video frames at zigbee receiver each having same matrix size 64X64.

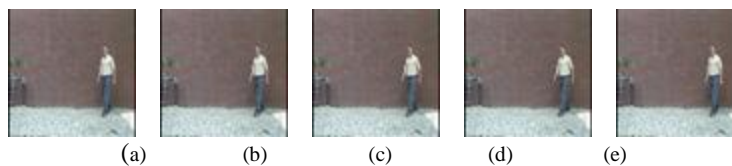

Figure 7 (a-e): Transmitted image frames (64 X 64) at 19200



Figure 8 (a-e): Received image frames (64 X 64) at 19200

After transmission and reception of video between two Xbee modules at 19200 bps, transmitted and received image frames are compared to obtain the following image

parameters namely MSE, PSNR, SSI and CR. All these parameters are obtained using Matlab and are listed out for all the frames as shown in Table 3.

Table 3: Image parameters at 19200 bps baud rate

Frame No.	Original frame size (KB)	Compressed frame size (KB)	CR (%)	MSE	PSNR	SSI
Frame 1	18.4	9.70	47.282	12.911656	25.917240	0.618791
Frame 2	18.7	9.70	48.128	12.981676	25.871961	0.617084
Frame 3	18.6	9.65	48.118	12.983870	25.870883	0.611750
Frame 4	18.7	9.64	48.449	12.388988	25.968139	0.611221
Frame 5	18.8	9.63	48.776	13.001938	25.858675	0.613323
Frame 6	18.8	9.61	48.882	10.506421	27.803265	0.667476
Frame 7	18.9	9.61	49.153	13.001149	25.860378	0.611721
Frame 8	18.3	9.69	47.049	13.080974	25.814170	0.605028
Frame 9	18.5	9.64	47.891	12.980698	25.878613	0.599133
Frame 10	18.6	9.65	48.118	12.582909	26.150243	0.622049

For getting more appropriate and accurate results with respect to transmission time, reception time, frame delay and frame loss, same video is transmitted several times between the two trans-receiver modules over the zigbee network serially. Readings are obtained as shown in Table 4 at 19200 baud rate. From Table 4, it can be observed that average

transmission time is approximately 6.135 sec, average reception time is 6.531 sec and average frame delay is 0.384 sec. All the frames are received at the receiver end every time the video is transmitted. It means all frames are received in each run, hence the frame loss is not present at 19200 baud rate.

Table 4: Average Tx-Rx time, frame loss and frame delay at 19200

RUN no.	Avg. TX Time (sec)	Avg. RX Time (sec)	Avg. Frame Delay (sec)	Frame Loss
RUN 1	6.13587	6.53414	0.39827	No
RUN 2	6.13494	6.52045	0.38551	No
RUN 3	6.1394	6.54503	0.40563	No
RUN 4	6.13618	6.55185	0.41567	No
RUN 5	6.13772	6.52471	0.38699	No
RUN 6	6.13836	6.526	0.38764	No
RUN 7	6.13674	6.51713	0.38039	No
RUN 8	6.13712	6.52138	0.38426	No
RUN 9	6.13712	6.51867	0.3881	No
RUN 10	6.13723	6.5208	0.38357	No

## VIII CONCLUSION

The image is first compressed, resized and then transmitted over zigbee at two different baud rates -viz- 19200bps and 38400bps. Comparison between two baud rates show that for the serial video transmission over zigbee in wireless sensor network, 19200bps is more reliable and efficient than 38400bps, as the frame loss is absent in the previous case in all runs. However the transmission and reception time and frame delay is lesser at 38400bps. The value of other image parameters like PSNR and SSI remains nearly the same at both baud rates. If the baud rate is reduced below 19200bps, the transmission and reception time increase drastically and if it is increased beyond 38400bps, the frame loss becomes prominent.

## REFERENCES

- [1] Maung, S., Shiraje, S., Islam, A., Hossain, M.M., Nahar, S. and Arif, Md.F.H. (2018) "Optimization of ZigBee Network Parameters for the Improvement of Quality of Service". Journal of Computer and Communications, vol.6, pp1-14. <https://doi.org/10.4236/jcc.2018.66001>
- [2] Ievgeniia Kuzminykh *et al.*; "Testing of Communication Range in ZigBee Technology", CADSM 2017, 21-25 February, 2017, Polyana-Svalyava (Zakarpattya), UKRAINE; 2017 IEEE; pp:133-136
- [3] Dan Tao *et al.*; "Data acquisition and transmission reliability for wireless image sensor networks", Tenth International Conference on Intelligent Information Hiding and Multimedia Signal Processing, IEEE 2014, pp: 819 – 822.
- [4] Chia-Hsin Cheng *et al.*; "Implementation of multi-channel technology in ZigBee wireless sensor networks", Computers and Electrical Engineering Journal, Elsevier. 2015; pp: 1-11.
- [5] M. Masurkar *et al.*, "LIFETIME MAXIMIZATION IN WIRELESS SENSOR NETWORK USING CROSS LAYER DESIGN: A DESIGN REVIEW" First International Conference on Emerging

Trends in Engineering and Technology, (ICETET) 2008 IEEE pp: 234-237.

- [6] P D Joshi, G M Asutkar, "Lifetime Enhancement of WSN by Heterogeneous Power Distributions to Nodes: A Design Approach", International Journal of Applied Information Systems (IJ AIS) – ISSN : 2249-0868
- [7] Xiaoxia Ren; Zhigang Yang, "Research on the key issue in video sensor network" *Computer Science and Information Technology (ICCSIT), 2010 3rd IEEE International Conference*, 2010, Volume: 7 pp 423 – 426
- [8] G. Mandyam *et.al.* "Lossless Image Compression Using the Discrete Cosine Transform", JOURNAL OF VISUAL COMMUNICATION AND IMAGE REPRESENTATION, Elsevier, Vol. 8, No. 1, March, pp. 21–26, 1997
- [9] Congduc Pham *et.al.* "Performances of Multi-Hops Image Transmissions on IEEE 802.15.4 Wireless Sensor Networks for Surveillance Applications" 9th International Conference on Wireless and Mobile Computing, Networking and Communications (WiMob) 2013 IEEE pp: 477-484
- [10] Dhote K., Asutkar G.M. (2016), "Enhancement in the Performance of Routing Protocols for Wireless Communication Using Clustering, Encryption, and Cryptography". In: Dash S., Bhaskar M., Panigrahi B., Das S. (eds) Artificial Intelligence and Evolutionary Computations in Engineering Systems. Advances in Intelligent Systems and Computing, vol 394. Springer, New Delhi
- [11] D. P. Mishra *et.al.* "An Application of Wireless Sensor Network in Intelligent Transportation System", 6th International Conference on Emerging Trends in Engineering and Technology, 2013, IEEE Computer Society pp:90-91.
- [12] Chahat Aggarwal and B. B. Gupta, "A Survey of Civilian Applications of WSN and Security Protocols" International Journal of Scientific Research in Computer Science and Engineering Vol.6, Issue.3, pp.56-66, June (2018)
- [13] Sharma, Shamneesh, Dinesh Kumar, and Keshav Kishore. "Wireless Sensor Networks-A review on topologies and node Architecture." International Journal of Computer Sciences and Engineering 1, no. 2 (2013): 19-25.

### Authors Profile

*Mrs. Mrunal Khedkar*, PhD Scholar, Priyadarshini Institute of Engineering & Technology, LTJSS, Nagpur. She has completed ME in Digital Electronics from S.G.B Amravati University (2013), B.E in Electronics and Telecommunication from R.T.M Nagpur University (2010).



She is corporate member of IEI. She has published more than 6 research articles. Her area of interest includes image processing, video processing, pattern recognition and wireless sensor network.

*Dr. G. M. Asutkar*, Vice-Principal Priyadarshini Institute of Engineering & Technology, LTJSS Group of Institutions ( PIET). He is Professor at Department of Electronics and Communications Engineering, PIET. He got Ph.D. from VNIT Nagpur, India.



He is senior IEEE member. He has completed his M.Tech. from VTU, Belgaum (Karnataka), India. He has published more than 25 research articles. He is active researcher in the field of Wireless Sensor Networks, network communication, routing protocols, and Block error diffusion for digital half toning for medical Images: Area Image Processing. He has actively participated in Organization of "KRITI 2004". He is member of the centralized cultural committee for 2005-06, Actively participated in Organization of "KRITI 2008", worked for TECH INDIA by Time Group.