

# Traffic Signal Optimization and Flow Control using Fuzzy Logic

Yashodhan Kumthekar<sup>1</sup>, Ankit Narendra Patil<sup>2</sup>, Yash Notani<sup>3</sup>, Jayshri Fating<sup>4</sup>, Soumitra Das<sup>5</sup>

<sup>1,2,3,4</sup>Dr. D. Y. Patil, School of Engineering, Charholi(Bk), Lohegaon, Pune. India - 412105

<sup>5</sup>PhD, Computer Engineering, Sathyabama University, Solingallur, Chennai. India – 600119

Available online at: [www.ijcseonline.org](http://www.ijcseonline.org)

Received: Apr/21/2016

Revised: May/04/2016

Accepted: May/18/2016

Published: May/31/2016

**Abstract**— This study proposes an intelligent traffic light system that would be capable of adjusting the traffic light based on density of traffic at a particular time. Fuzzy logic could be used to manage the flow of vehicles at traffic signals and ensure efficient flow of vehicles, reducing traffic congestions at peak time. This could be done by analyzing traffic density by analyzing inputs via sensor that could be fitted at signals. This will then be used by microcontroller to set the green signal for varying intervals of time so as to clear the traffic at signals as efficiently as possible. This approach could be implemented to dynamically manage the traffic signal and would prove efficient to help reduce the day to day traffic congestion problems. This study mainly aims to overcome this problem.

**Keywords**—Arduino Mega 2560 microcontroller, Embedded software, Fuzzy logic, Fuzzy control, Ultrasonic transducers, Zigbee.

## I. INTRODUCTION

The system is designed to analyze the traffic at four way junction and adjust green light intervals for **variable densities** of traffic. E.g. If at a traffic signal number of vehicles coming from north & south is too much and that of coming from the east & west is very little, the green light interval for north & southbound traffic will be longer and that for east & westbound traffic will be shorter.

The system is comprised of **sensors** and a **microcontroller**. Sensors are fitted at distinguished positions at the four way junction. The sensor measures the density and communicates the same to a microcontroller. Microcontroller will use these to adjust timing intervals of green lights.

Moreover, we have also implemented a feature to ensure **integrity of traffic rules** at the signal. A **spike strip** will be introduced at the front of each lane before the zebra crossing. The spike strip will be **engaged** once the signal goes red. Once the strip is engaged, if any vehicle attempts to cross the strip, the vehicle would get damaged. Once the light goes green the spike strips will be **disengaged** and vehicles could move freely.

Thus we have developed a system that ensures efficient flow of traffic on the road and also ensures integrity of traffic laws at the four way junction.

## II. RELATED WORK

### A. Existing System

Since the signal system has been introduced, premier development lead to introduction of fixed time signals, i.e.

the ones we see today on the road. These signals have preset time intervals and work only according to them regardless of the traffic scenario.

*International Development:* Such a system is implemented in Kuala Lumpur, Malaysia. The system monitors the traffic density using proximity sensors and adjusts the signals dynamically. Kuala Lumpur use to have world's biggest traffic jams at a time, but now after installation of such systems they have succeeded to control their traffic at a greater extent ensuring lesser traffic congestion scenario.

A Delhi based firm is currently testing same system at one of the junctions in the City. The system comprises of Cameras that monitor traffic density and then processes the camera imaging to determine the traffic density and change the signals. The system results are although good, but the system bears higher installation costs as well as could be expensive to operate.

### B. LITERATURE SURVEY

(1) Md. Shabiul Islam (2006), "Hardware Implementation of Traffic Controller using Fuzzy Expert System"; IEEE Conference at Ambleside  
Description: This paper presents the design of traffic controller hardware using fuzzy expert system algorithm for traffic light controlling purpose. This system becomes more efficient with the help of knowledge.

(2) Ms. Promila Sinhmar (2012), Rawal Institute of Engineering And Technology Zakopur "Intelligent Traffic Light And Density Control Using IR Sensors And

Microcontroller” in International Journal of Advanced Technology & Engineering Research (IJATER).

Description: This system uses a microcontroller along with a set of IR transmitters and receivers on either side of road to detect presence of vehicles up to a certain length. This is a basic edge detection technique to determine the length of the queue on a road and then adjusts the green light interval accordingly.

(3) Monish Puthran (2015), “Smart Traffic Signal” in (IJCSIT) International Journal of Computer Science and Information Technologies.

Description: This system involves closed loop control imaging of all four roads. Then process the obtained image and apply canny edge detection techniques to determine the length of vehicles and adjust green light.

(4) Ashwini Basavaraju (2014), “Vehicle density sensor system to manage traffic” in IJRET: International Journal of Research in Engineering and Technology.

Description: This study proposed an approach to determine the traffic at signal using various inputs like sensors, PC, etc and transfer the same microcontroller which then processes the input and gives appropriate input to Signal.

(5) Abdelrasoul Jabar Alzubaidi (2014), “Design of semi-automatic traffic light control system” in International Journal Of Scientific & Technology Research.

Description: This paper makes use of sensors, microcontroller and GSM modem which provides real time benefit to the system. This system is developed using microcontrollers ATMEGA32. To monitor the traffic light system and make it more efficient, they have designed an intelligent Traffic control system.

### C. GENERAL DISCUSSION OF REVIEW WORK

After studying above research papers we concluded that the systems developed by them are although perfect, but some systems are comparatively costly and complex too. One of the above research paper implemented system using camera to capture the image, this system is although very reliable but costly as well as involving higher space complexity. Another system implemented various sensors at a time along with various computers to provide input data to microcontroller, system developed seems to be very complex. One of the developed systems makes use of IR sensors which is very cost efficient, but IR sensors are not always reliable as they misbehave in sunlight. We want to implement a system which will be easy to set up, and must be reliable, comply with environmental factors and at the same time must also be cost efficient.

### III. PROBLEM STATEMENT

Ever-growing cities worldwide these days are facing a big question of traffic congestions. These congestions lead to increase in fuel consumption, pollution and wasting lots of time. Develop a system that has ability to overcome these problems. Make a system that will manipulate traffic signals according to present traffic scenario at the four way junction.

### IV. OBJECTIVES

- An intelligent traffic light system.
- Provide wireless communication for easy implementation as well as to reduce the setup cost and complexity.
- Optimize the flow of traffic efficiently.
- Robust and dependent system
- 24 x 7 service capability.
- Ability to sense the density of traffic more accurately.
- Operation of signals for proper intervals using Fuzzy Logic Controller.
- Avoid signal violators by engaging and disengaging Spikes before Zebra crossing.
- Maintain integrity of Traffic law.
- Capability to communicate information of signal violation.

### V. MATERIAL AND METHODS

#### A. PROPOSED SYSTEM

We have implemented a smart traffic signal system that is capable of adjusting signal timings to efficiently control the flow of vehicles on four way intersection to reduce traffic congestion and reduce travelling time.

We also ensure that system works efficiently even at peak hours. We implemented this by installing Ultrasonic sensors and an Arduino Mega 2560 microcontroller at signals. The Arduino functions as a fuzzy logic controller, which is responsible for adjusting traffic light intervals. It has the ability to interface and interact with sensors.

Arduino boards are programmed using the Arduino IDE that is provided by Arduino community for free. The code is called a sketch but is actually a C/C++ function set.

There is a set of ultrasonic sensors that is used for object detection with the help of two parameters echo and trigger. These sensors are installed appropriately to calculate the limits of cars in a particular lane. The limit would decide the density of traffic i.e. less traffic, moderate traffic or heavy traffic. They will communicate the appropriate results to the microcontroller.

Our prototype is scaled down model of a real life traffic signal scenario. It consists of an Arduino MEGA 2560 and a set of HC-SR04 ultrasonic sensors which are used to develop the prototype. The sensors measure the traffic density and convey the same to microcontroller using ZigBee. Microcontroller then allots an appropriate time interval to the traffic signal.

The same model could be scaled up with greater capacity sensors and ZigBee devices and would serve the purpose equally.

## B. MATERIAL USED

### I. ARDUINO MEGA 2560

Arduino Mega 2560 is a microcontroller board consisting of an ATmega2560 processor clocked at 16MHz, 54 digital input/output pins, 16 analog inputs and an onboard 256 kilobytes of flash memory. Microcontroller is a Linux based system. It is programmed as a fuzzy logic controller to control the traffic light system.

### II. ULTRASONIC SENSORS

HC- SR04 ultrasonic sensors are used for object detection. It is used to detect object in a particular lane. It can measure distance within range of 2cm to 3m. It works efficiently in any visibility condition and are least affected by any external environmental factors.

### III. SERVO MOTOR

Servo motor is a rotator actuator that allows precise control of movement. In this system servo motors are used for moment of spikes, which are engaged during red light signal and are disengaged when signal turns to green. The servos are connected to the main Arduino which instructs them when to engage and disengage. Each lane has its own Servo motor for spikes.

### IV. ZIGBEE

Xbee S2 modules are used as point to point wireless communication. It has a range of 120 meters over line of sight and can send small chunks of data efficiently and fast as well. These are connected with sensors and are responsible to send data collected by sensors to the microcontroller

## C. SYSTEM ARCHITECTURE

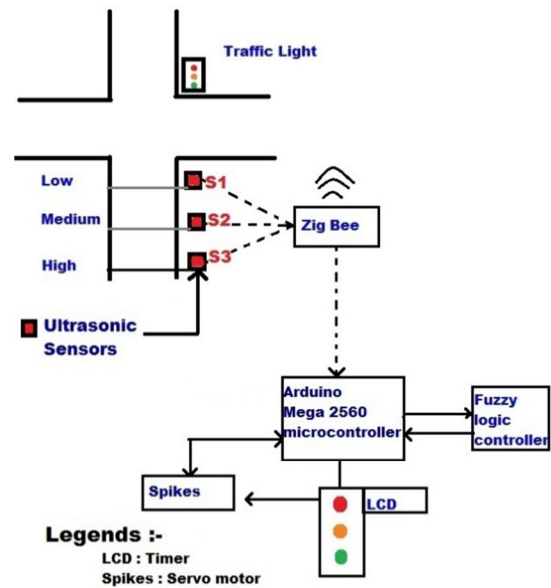

## D. METHODOLOGY

### I. FUZZY LOGIC:

Fuzzy logic allows for implementation of real-life rules similar to the way humans would think. For example, humans would think in the following way to control traffic situation at a certain junction: "if the traffic is heavier on the north or south lanes and the traffic on the west or east lanes is less, then the traffic lights should stay green longer for the north and south lanes". Such rules can be easily accommodated using the fuzzy logic controller. The beauty of fuzzy logic is that it allows fuzzy terms or that it allows to define rules for degree of truth e.g. conditions such as "heavy", "less", and "moderate" can be quantized and understood by the computer. Fuzzy logic traffic lights control is an alternative to conventional traffic lights control which can be used for a wider array of traffic patterns at an intersection. This helps the controller to deduce the traffic densities in the lanes and allows a better assessment of changing traffic patterns.

### E. REAL TIME VIEW

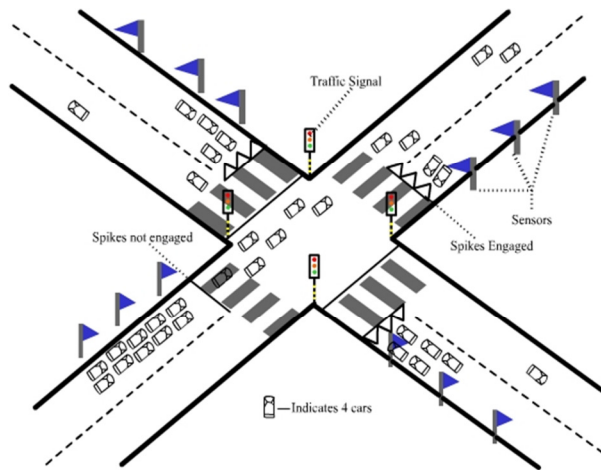

## VI. SCOPE

- This can be implemented in major cities.
- This project can further implement advancements like implementing special functioning in case an ambulance or emergency vehicle has to pass. In such cases the lights could be forced to go green irrespective of traffic densities.
- Further advancements can allow multiple signal interfaces to communicate with nearby interfaces to manage traffic at a greater level.
- Violation reporting could be implemented where if any one tries to violate the signal the same could be reported to the nearest police station so that appropriate action could be taken. This would also discourage the violators thus restoring integrity.
- Further the controllers could be advanced for self-learning using artificial intelligence methods for deducing even more patterns and more efficient functioning even at different hours of the day.

## VII. CONCLUSION

The system we have developed provides very simple and efficient way to dynamically handle the traffic signal system at four way junction. The system is cost efficient and less complex. The system works efficiently even during peak hours and is quite robust as well. Spikes help to avoid traffic law violators. Thus the system overall demonstrates efficient functioning and meets all the

functional requirements. It will also help to reduce travelling time as well as fuel consumption of commuters and thus help to reduce pollution as well.

## VIII. ACKNOWLEDGMENT

We specially thank our guide Prof S S Das sir for being such a great support and for mentoring us plan and develop such an innovative idea. He was always there for guidance and moral support. Also, we thank our college Faculty and our friends for their help whenever needed.

We thank our college Dr D Y Patil School of Engineering for providing us with such a platform to implement our idea.

We also thank our parents to stand by us and support us throughout the project.

## IX. REFERENCES

- [1] Md. Shabiul Islam, ; M. S. Bhuyan ; Md. Anwarul Azim ; L. k. Teng, "Hardware Implementation of Traffic Controller using Fuzzy Expert System" in IEEE conference Multimedia University Malaysia, E-ISBN : 0-7803-9719-3, September 2006.
- [2] Bilal Ahmed Khan, Nai hyan Lai, "An Intelligent Traffic Controller Based on Fuzzy Logic" in AsiaPacific University of Technology and Innovation, ISBN: 978-0-9853483-8-0 ©2013 SDIWC, 1996.
- [3] Ms. Promila Sinhmar, Rawal Institute of Engineering And Technology Zakopur "Intelligent Traffic Light And Density Control Using IR Sensors And Microcontroller" in International Journal of Advanced Technology & Engineering Research (IJATER), ISSN NO: 2250-3536, 2012.
- [4] Monish Puthran, Sangeet Puthur, and Radhika Dharulkar "Smart Traffic Signal" in (IJCSIT) International Journal of Computer Science and Information Technologies, Vol. 6 (2), 2015, 1360-1363, 2015.
- [5] Ashwini Basavaraju, Senhalata Doddigarla, Navitha Naidu, Shruti Malgatti "Vehicle density sensor system to manage traffic" in IJRET: International Journal of Research in Engineering and Technology eISSN: 2319-1163 | pISSN: 2321-7308, 2014.
- [6] Abdelrasoul Jabar Alzubaidi, Arwa Abdel Mohsen Ahmed Hassan, "Design of semi-automatic traffic light control system" in International Journal Of Scientific & Technology Research Volume 3, Issue 10, October 2014 Issn 2277-8616, 2014.