

# Reliability Constrained Energy Sharing Mechanism Among Smart Homes

Sonvir Singh<sup>1\*</sup>, Tushar Srivastava<sup>2</sup>

<sup>1</sup> Department of Computer Science & Engineering, Visvesvaraya National Institute of Technology, Nagpur, India

<sup>2</sup> Department of Electrical Engineering, Delhi Technological University, Delhi, India

\*Corresponding Author: [sonvirsingh036@gmail.com](mailto:sonvirsingh036@gmail.com)

Available online at: [www.ijcseonline.org](http://www.ijcseonline.org)

Accepted: 07/Jun/2018, Published: 30/Jun/2018

**Abstract**—According to the load curve, the load of each home is changing with the time. During the time in which load is less compared to the Generation in this condition smart home has an opportunity for energy sharing among the smart homes which are equipped with energy sources such as rooftop Solar Cells, EVs. In the proposed energy sharing scheme, the enticement is given in terms of priority to the SHs which participate as an energy provider. EVs energy also use in sharing if has access energy stored in the batteries then requirement. In this paper the Priority-Based energy sharing approach is discussed among the nearness Smart Homes (SHs) which are located in the physical proximity of each other. The approach is a non-pricing based. The Distributed Network Management System helps the SHs in sharing energy on the basis of Demand, past energy contribution and reliability factor. The SHs acting as an energy provider will be rewarded in respect of money and priority index if require energy in future. The simulation result of energy sharing mechanism in practical world is shown in this paper.

**Keywords**— Smart homes, Renewable Energy, Nash equilibrium, Game theory, Energy sharing mechanism.

## I. INTRODUCTION

Smart Homes (SHs) are generally equipped with the Solar panel and also has Electrical Vehicles (EVs). EVs and other types of hybrid vehicles have the capability to connect the grid to charge their batteries, known as a plug-in vehicle. They have also the capability to share energy with other SHs. The plug-in vehicle can be both a threat and an opportunity for the power grid [1]. While they impose huge loads to the grid, they are a major threat. From the other point of view, they can act as responsive load and energy storage, thus they provide a good opportunity. Therefore, by proper control, this will help in providing the energy at the time of the outage.

Smart homes have own electricity generation but major goals provide the suitable intelligent control to the SHs for sharing the access energy or take when require. As per Survey[2], the electricity usages for domestic purpose is around 30% and at the same time usage awareness and scheduling optimization alone have potential to reduce consumption by 15% in private household. The demand of energy increasing day by day due to the industrialization and population in the developing countries. Due to awareness about the global warming and bad condition of environmental, people are looking for clean and green energy especially solar energy which is available in abundant during most of the time in a year. In order to achieve sustainable development, the developing countries

must reduce the dependency on the energy sources which emits high carbon. Recently Government working on reducing the burden of the main grid by promoting the renewable source of energy like rooftop Solar Panel. This allows an individual household to generate its own energy for its use [3]-[5].

The intermittent behavior of the solar energy usually mismatches between the energy generated and load demand. Also due to load variation of different individual homes. Sometimes, home requires more energy than own generation and sometimes less, this cause mismatch condition. To remove this mismatch condition, they store this surplus energy in batteries or share with the neighborhood homes. However, storing energy may not be a cost effective solution due to high battery cost and postponing the operation of the device may disturb the consumer comfort. The above approach has their own limitation like require large batteries, the burden on the main grid, negatively affecting daily activities of people [6].

In order to solve the above mismatch problem, we have proposed an energy sharing mechanism for the SHs. In energy sharing, the homes having the surplus energy they share with other demanding homes at the given interval of time. A local smart distribution system can manage the surplus energy at the consumer end and communicate with the Distributed network management system. SHs can share their surplus energy with other homes by using the management system infrastructure. Based on this

infrastructure, we have designed the priority based energy sharing mechanism that benefits both consumer and the main grid. The grid provides the fare energy trading mechanism to SHs to share the surplus energy.

The existing mechanism to solve the energy mismatching problem in SHs classified into the following three categories: (1) storage of surplus energy [7], (2) surplus energy trading with the main grid [8], (3) shifting of load [9]. In the first approach, each SH needs to be equipped with the heavy batteries to store the energy for the future usage [10]. The cost of purchasing and maintaining batteries can well exceed the benefits of employing a solar energy system for an average family in the US [11]. This is true in most part of the world. In the second case, the selling of energy to the main grid at the buying price and earn profit but this approach destabilizes the main grid by making the balance between the supply and demand [10]. The third approach of shifting consumer load may not be a popular choice which will affect the people’s living and comfort.

In order to overcome the disadvantage of the above mechanisms, [10] proposes an approach to share surplus renewable energy. For this, we require extra infrastructure to connect all the homes and provide the simple mechanism to share their energy. However proposed mechanism has some limitations: 1. It does not guarantee fairness among all SHs, 2. It requires extra infrastructure. For the fairness, we add the reliability factor in the priority index which attracts more SHs to contribute the surplus energy to the grid.

In this paper, we have proposed priority based energy sharing mechanism which is free from the above limitations. We do not need to build extra infrastructure for this mechanism because we are using the roof for mounting the solar panel and for the EV, all home having separate space for vehicle standing. The mechanism allows simultaneously energy trading among all SHs and provides the incentives in terms of priority and money to the seller home but in this paper, we do not consider the money factor. The proposed algorithm allows all buyers to decide their strategy to buy energy from the surplus. The noncooperative game is established between the buyers. The proposed mechanism reduces the burden of the main grid and will promote the renewable source of energy and its utilization at the low cost.

The rest of the paper organized as follows: Section-II present Energy Sharing Mechanism Model, Section-III Proposed Strategies for Smart homes, Section-IV Simulation Analysis, Section-V Result and discussion, Section-VI Conclusion of Paper.

## II. ENERGY SHARING MECHANISM MODEL

In this paper, we have considered a group of a home in a small geographical area connected to a distributed network as shown in a Fig-1. All SHs are connected with the grid which has two line one is power line and other is

communication line. MACE (Management At Consumer End) agent decide which home acts as buyer or seller at given interval of time. All SHs also connected to the main grid and can exchange energy with the main grid.

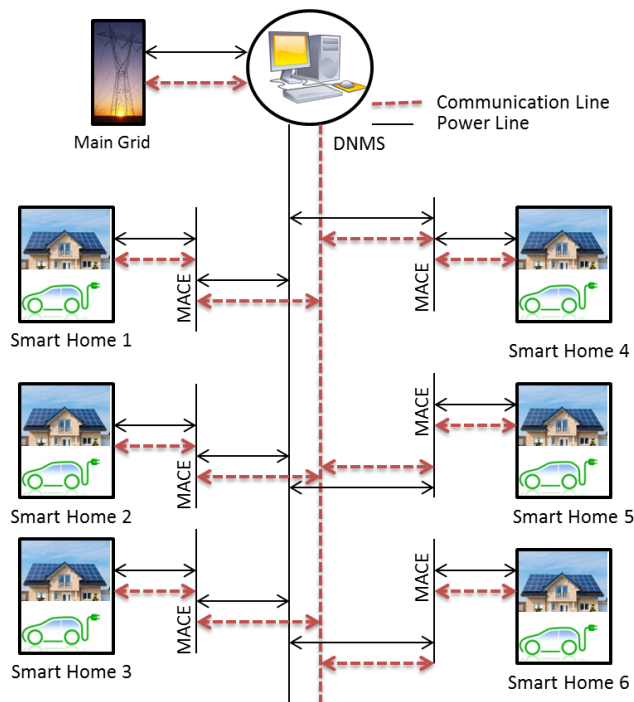

Figure 1. Energy Sharing Mechanism Model

In the proposed system, assumed that there are N SHs such as  $SH = \{1, 2, 3, \dots, N\}$ . In the given interval each SH able to generate  $G_i$  through solar panel and EVs and each SH having to load  $L_i$ . MACE (Management At Consumer End) agent having data of Generation and load of each SH. If  $G_i > L_i$ , this  $i^{th}$  SH is called as an Energy Seller (ES). Let  $x$  be the set of all such energy seller. After serving on load the SH have excess energy which defines as  $E_{i,excess} = (G_i - L_i) \geq 0, i \in x$ . DNMS control the connection between the SHs and main grid. Surplus energy is distributed to SHs on the basis of priority index. Here game theory plays important role in energy selling to the competitive environment.

If  $G_i < L_i$ , this shows that SH needs to buy extra energy either from the smart home acting as energy seller. These SH act as an energy buyer (EB). Let  $y$  is set of SH which acts as an energy buyer. the required energy define as the  $E_{i,req} = (L_i - G_i) \geq 0, i \in y$ . DNMS also have the energy to give to the other EB SHs as per requirements. DNMS store energy in batteries, flywheel at the time, when all SHs acting as an energy seller [11].

$$E_{ex} = \sum_{k \in x} (G_k - L_k) \tag{1}$$

Priority index  $P_i$ , denote the priority index of  $i^{\text{th}}$  SH while buying energy from the surplus energy. Priority index equation is given in next section. At the initial level, SH act as energy seller or energy buyer it will be decided by the MACE agent, then MACE agent share the data with the DNMS through a communication line. On the basis of priority index and game theory, DNMS decides to give the energy to SH buyers. DNMS also help in connecting the grid to main grid if the load is more than the generation of all SHs.

### III. PROPOSED STRATEGIES FOR SMART HOMES.

In this section, various strategies for the SHs who are acting as EB (Energy Buyers) are discussed. As per requirement, each SH decided its strategy for buying the energy from the DNMS using the game theory algorithm. DNMS allocate energy to the buyer SH according to the priority index.

#### A. Priority index calculation.

Priority index is an important parameter in the proposed sharing energy mechanism. The PI can be calculated as:

$$PI_i = \frac{Contribution_i}{Contribution_{total}} + \frac{Demand_i}{Demand_{total}} + R \quad (2)$$

R is reliability factor. Reliability factor defines as:

$$R = e^{-\lambda t} \quad (3)$$

Where,

R = Reliability as a function of time (sometimes shown as R(t).

e = Euler's constant ( $\approx 2.71828$ )

$\lambda$  = Failure rate (assumed to be a constant during the useful

life period).

t = Time.

$$\lambda = \frac{dN_f}{dt} \frac{1}{N_s} \quad (4)$$

Where,

$\lambda$  = Failure rate

$N_f$  = Number of time SH failed to provide energy in past

during given period.

$N_s$  = Number of surviving during given period

Here, equal importance is given to the contribution, local demand load, and reliability. However, DNMS assign higher importance to the contribution compare to the demand load and reliability. It depends upon the DNMS [11].

#### B. Strategy for Smart Homes Acting as Energy Buyers.

The competition between SHs acting as an EB can be formulated as a continuous strategic for a game. The existence and uniqueness of Nash Equilibrium (NE) along with closed-form expressions of the game are given in [12], [13].

Each buyer has its own need and they require more energy as much possible as from the DNMS. Thus, the utility functions of all buyer SHs i.e. EB is given as,

$$u(e) = \arg \max \left[ \sum_{i \in \mathcal{I}} PI_i^\beta \log \left( 1 + \frac{EA_i}{e_i} \right) \right] \quad (5)$$

$$\text{s.t. } 0 \leq EA_i \leq e_i, \quad \therefore i \in \mathcal{I}$$

$$\sum_{i \in \mathcal{I}} EA_i \leq E_{ex} \quad (6)$$

Where  $e_i$  is the demand strategy and EA is the amount of energy allocated to the  $i^{\text{th}}$  EB. The competition in the buyer to drag more energy from the DNMS they play a non-cooperative continuous strategic form of the game. The game theory is used to play a non-cooperative game between the buyers. The algorithm 1 give the Nash equilibrium i.e the optimal strategies for each buyer of smart home [14].

### IV. SIMULATION ANALYSIS.

In the proposed sharing mechanism we have considered the market and home levels for sharing the energy in a group of SHs as shown in Fig-1. The market level contains the sharing between the SHs and with the main grid. Home level deals with the energy sharing balance in a group of SHs. For the simulation purpose, we have considered the time block of 10 min duration, in a single day, there are 144 blocks. During each block generation and demand remain constant. In each block generation and demand must be constant, first 5 min are for negotiation and left 5 min interval for to fulfill the promise which takes in negotiation period. The outcome of the negotiation interval is set of the agreement which will be implemented in the next interval. The Bar Chart is shown in Fig.2.

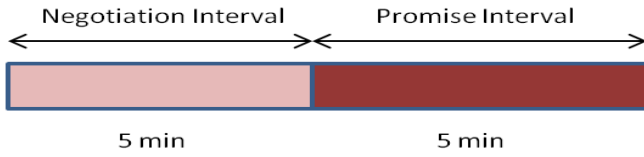

Figure 2. Bar Chart

## Algorithm 1: Optimal Strategy for Energy Buyer's

- Arrange all EB SHs and their  $x$  vector by the value of  $\frac{E_{req,i}}{PI_i^\beta}$  in ascending order.
- Initialize filling index  $j=1$ ;  $N=|Q|$ ;

$$\text{Filling width } w = \sum_{i \in y} PI_i^\beta ;$$

$$\text{Energy remaining } E_{rm} = E_{ex} ;$$

$$\text{Energy height } \eta = 0 ;$$

$$E_{req,N+1} = \infty \text{ and } P_{N+1} = 1 \text{ for handling the exceptional case.}$$

While ( $E_{rm} > 0$ )

$$\circ \text{ If } \left( w \left( \frac{E_{req,i}}{PI_i^\beta} - \eta \right) < E_{rm} \right)$$

$$E_{rm} = E_{rm} - w \left( \frac{E_{req,i}}{PI_i^\beta} - \eta \right) ;$$

$$\eta = \frac{E_{req,i}}{PI_i^\beta} ; w = w - PI_i^\beta ; e_j = E_{req,j} ;$$

$$j = j + 1$$

◦ else

$$\eta = \eta + \frac{E_{rm}}{w} ; E_{rm} = 0 ;$$

for  $k=j$ ;  $N$

$$e_k = \eta PI_i^\beta ;$$

End

Rearrange the optimal strategy of each EB SH in the original order.

## A. Functioning.

Each SH is managed by the MACE agent. The sequence of events involved in energy sharing mechanism.

- *Negotiation Interval*- DNMS will announce the start of discussion period with all SHs
- *Collection of Data*- Each MACE collect the local generation and local demand data and send the details to the DNMS for the next block. On the basis of data information, DNMS will pass the information regarding the surplus energy to the registered SHs as Energy Buyers.
- *Role of SHs*- Based on the generation and load demand, MACE agent act as energy seller, buyer or neutral. If SHs have more generation than the demand, in this case, SH act as Energy seller otherwise acts as an Energy buyer. If generation and demand is equal then SH act as a neutral. On the basis of this DNMS decide the role of SHs. MACE agent take a decision on the basis of Algorithm-1 to buy the energy from the nearness SH acting as ES.
- *Role of DNMS*- DNMS will aggregate the total energy available for the seller. It will also calculate the priority index of all SHs. It also keeps the past records of all SHs which help in calculating the PI. If the energy remaining is less than the energy required, it will buy the extra energy from the main grid at the normal prize. In case of excess energy available after the distribution among the buyer, it will sell to the main grid.
- *Confirmation of the Energy sharing* - Conformation done by the DNMS after successful sharing of energy among the SHs.
- *Process Stop*- DNMS announces 'stop negotiation', policies are made. These policies are released at the beginning of next interval.

## V. RESULT AND DISCUSSION

For the simulation, we have considered the community of 6 smart homes. The data of first three block is given in the Table-I. All SHs are equipped with the roof mounted solar panel and EV (Electrical Vehicle). Energy generated by solar cell and EV is mentioned separately. All SHs has a different load which is due to the different lifestyle. On the basis of load and generation, we decide the role of each SHs in the given interval.

In block 1, only SH2 and SH6 act as an Energy Buyer and other SHs act as an Energy Seller. Total energy for selling is 18.4 kW which is more than the amount of energy required by the buyers SHs. The required energy is 3.5 kW. Left energy 14.9kW is given to main grid at the normal price or DNMS stored this energy in their storing unit. The distribution of 3.5 kW energy among the SHs irrespective of priority index. In block 2, total energy generation is 6.5kW and demanding energy by EB is 11.1kW. In this case, the demand is more than the generation. 6.5kW energy is distributed among the SHs is done on the basis of priority

index and algorithm-1. Balance required 4.6kW energy is taken from the main grid by DNMS. Main focus is given to reliability factor which define reliability of SHs in respect of Energy sharing and policy making in past period at the time of energy sharing.

Table 1. Micro Grid Data of Smart Homes.

BL K	SH	Total load (L)(kW)	Total Gen. (G)(kW)		(G-L)(kW)	Role	$E_{rm}$ (kW)
			SP	EV			
1	1	8	12	0.5	+4.5	ES	18.4
	2	7	5	0.7	-1.3	EB	
	3	9	10	00	+1	ES	
	4	5	14	1	+10	ES	
	5	3	5	0.9	+2.9	ES	
	6	5	2	0.8	-2.2	EB	
2	1	12	10	00	-2	EB	6.5
	2	10	8	0.2	-1.8	EB	
	3	5	9	0.5	+4.5	ES	
	4	8	5	0.8	-2.2	EB	
	5	12	6	0.9	-5.1	EB	
	6	9	10	1	+2	ES	
3	1	4	6	0.5	+2.5	ES	17.3
	2	10	9	0.3	-0.7	EB	
	3	6	15	0.6	+9.6	ES	
	4	7	5	0.1	-1.9	EB	
	5	9	9	00	00	N	
	6	10	15	0.2	+5.2	ES	

Note: - sign indicates deficiency of energy and +sign indicates excess of energy, EB- Energy Buyer, ES- Energy Seller.

In the proposed study, DNMS act as an aggregator who collects all surplus energy from ES and distributes among the EB using the proposed algorithm. In the block 3, SH1, SH3, SH6 acting as ES with the total energy of 17.3 kW. At the same time SH2, SH4 acting as EB with the energy demand of 2.6kW. SH5 is acting as neutral; this smart home is not participating in the selling or buying the energy. In the block 3, The total generation energy is more than the demand energy. Irrespective of priority index all EB

receives 2.6 kW and remaining 14.7 kW will be shared with the main grid. Demand load, Generation and behavior of smart home shown in Fig-3.

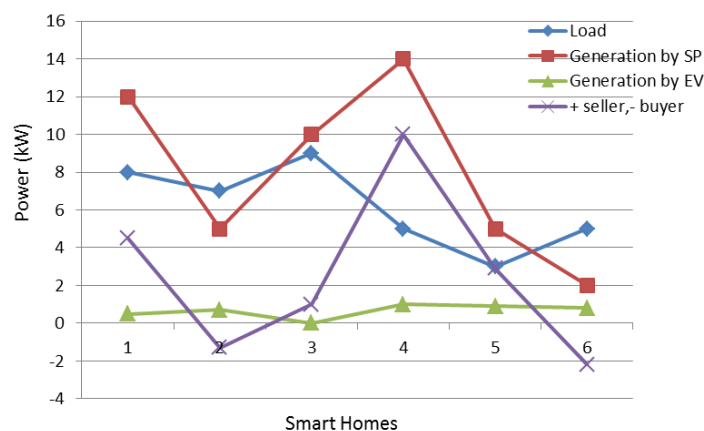

Figure 3. Smart homes Vs Power (kW).

## VI. CONCLUSION

In this paper, new energy sharing mechanism is proposed among the Smart Homes, mainly focus on the reliability factor i.e. past reliability of each Smart Home during sharing of energy. The proposed mechanism is the non-pricing approach. It is simple and fair enough to motivate the smart home to share the energy with the other smart home. All smart homes is equipped with the rooftop solar panel and electric vehicle and energy sharing done on the basis of priority index which cares simultaneously load demand, reliability and past contribution made by the smart home. This also ensures fair distribution among smart homes acting as Energy buyers. In future, it will reduce the burden of main grid and also provide the energy at the local level during an outage or in a fault condition.

## REFERENCES

- [1] Sonvir Singh, Tushar Srivastava, Sudhir Kumar Singh. "Ehybrid Vehicle – Next Generation and Energy Efficient Vehicle", Volume 5, Issue IX, International Journal for Research in Applied Science and Engineering Technology (IJRASET) Page No: , ISSN : 2321-9653,2017.
- [2] Lior, Noam. "Sustainable energy development: the present situation and possible paths to the future." Energy35.10 (2010): 3976-3994, 2009.
- [3] Comprehensive Policy for Grid-connected Power Projects based on New and Renewable (Non-conventional) Energy Sources - 2015. Available: <http://www.mahaurja.com>.
- [4] Methodology for the installation of projects under the comprehensive policy for grid-connected power projects based on New and Renewable (Non-conventional) Energy sources -2015. Available: <http://www.mahaurja.com>.
- [5] Maharashtra Electricity Regulatory Commission, Net Metering for

- Roof-top Solar Photo Voltaic Systems Regulations, 2015. Available: <http://www.mercindia.org.in/Regulations.htm>.
- [6] Wang, Huangxin, Jean X. Zhang, and Fei Li. "Incentive mechanisms to enable fair renewable energy trade in smart grids." Green Computing Conference and Sustainable Computing Conference (IGSC), 2015 Sixth International. IEEE, 2015.
- [7] D. J. Unger, "Want a solar home? consider batteries." <http://www.csmonitor.com/Environment/2013/0427/Want-a-solar-home-Consider-batteries>, 2013.
- [8] Barbato, Antimo, et al. "House energy demand optimization in single and multi-user scenarios." Smart Grid Communications (SmartGridComm), 2011 IEEE International Conference on. IEEE, 2011.
- [9] Schulke, Anett, Jochen Bauknecht, and Johannes Haussler. "Power demand shifting with smart consumers: A platform for power grid friendly consumption control strategies." Smart Grid Communications (SmartGridComm), 2010 First IEEE International Conference on. IEEE, 2010.
- [10] T. Zhu, Z. Huang, A. Sharma, J. Su, D. Irwin, A. Mishra, D. Menasche, and P. Shenoy, "Sharing renewable energy in smart microgrids," in ACM/IEEE ICCPS, pp. 219–228, 2013.
- [11] A. Jossen, J. Garche, and D. U. Sauer, "Operation conditions of batteries in PV applications," Solar Energy, vol. 76, no. 6, pp. 759 – 769, 2004.
- [12] Jadhav, A. M., & Patne, N. R. Priority-Based Energy Scheduling in a Smart Distributed Network With Multiple Microgrids. IEEE Transactions on Industrial Informatics, 13(6), 3134-3143, 2017.
- [13] S. Park, J. Lee, S. Bae, G. Hwang, and J. K. Choi, "Contribution-Based Energy-Trading Mechanism in Microgrids for Future Smart Grid: A Game Theoretic Approach," IEEE Trans. Ind. Electron., vol. 63, no. 7, pp. 4255–4265, July, 2016.
- [14] P. J. Reny, "Non-cooperative games: Equilibrium existence," in New Palgrave Dictionary of Economics, 2nd ed., Palgrave Macmillan, 2008.

---

### Author's profile

Sonvir Singh received B-Tech degree in Electrical and Electronics Engineering From Gautam Buddh Technical University, Lucknow, Uttar Pradesh in 2012. He is Currently working in Visvesvaraya National Institute of Technology, Nagpur. His research interests include Electric and Hybrid Vehicles, Renewable Sources of Energy, Solar Panels and Smart Grid. His main research work focuses on Smart Grid and Maximum Power Point Tracking in Solar Panel. He has 5 years of Technical as well as Research Experience.



Tushar Srivastava received B-Tech degree in Electrical and Electronics Engineering From Gautam Buddh Technical University, Lucknow, Uttar Pradesh in 2012. He is Currently pursuing M-Tech (power system) from Delhi Technological University, Delhi . His research interests include Electric and Hybrid Vehicles, Renewable Sources of Energy, Solar Panels, Wind energy load and price forecasting and Smart Grid. His main research work focuses on wind power load ,price forecasting, Smart Grid and Maximum Power Point Tracking in Solar Panel. He has 4 years of Experience in the field of solar panels installation and inspection.

---

