

Design and Implementation of Efficiency Improved DC-DC Boost Converter

Jeneesh Scaria^{1*}, Preethy Sebastian², Susan V. Nanan³

^{1,2,3}Department of Electrical and Electronic Engineering, Mangalam College of Engineering, Kerala, India

Available online at: www.ijcseonline.org

Received: 22/Nov/2016 Revised: 07/Dec/2016 Accepted: 20/Dec/2016 Published: 31/Dec/2016

Abstract—This paper proposes the design and simulation of a DC-DC Boost converter employing PID controller, enhancing overall performance of the system. The main objective of a DC-DC converter is to maintain a constant output voltage despite variations in input/source voltage, components and load current. Designers aim to achieve better conversion efficiency, minimized harmonic distortion and improved power factor while keeping size and cost of converter within acceptable range. A simple PID (Proportional, Integral and Derivative) controller has been applied to a conventional Boost converter and tested in MATLAB-Simulink environment achieving improved voltage regulation. The proposed closed loop implementation of the converter maintains constant output voltage despite changes in input voltage and significantly reduces overshoot thereby improving the efficiency of the converter. The output of this investigation has the potential to contribute in a significant way in electric vehicles, industry, communication and renewable energy sectors.

Keywords— DC-DC converter; voltage regulation; Boost converter; overshoot; PID; Block Diagram Reduction; stability

I. Introduction

Power Electronics is ushering in a new kind of industrial revolution due to its versatility in terms of fields of application like energy conservation, renewable energy system, bulk utility energy storage, electric and hybrid vehicles and industrial automation. When it comes to power conversion, a DC-DC converter plays a significant role resulting in widespread applications in cellular phones, laptop computers, LED drivers, maximizing energy harvest for photovoltaic systems and for wind turbines, electric vehicles, hydro power plants and many more [1]-[4]. This widespread application requires that the converter should achieve highest efficiency, minimized total harmonic distortion (THD) and improved power factor (PF) at the load side while at the same time reducing size and cost of the device and increasing availability [5]-[8].

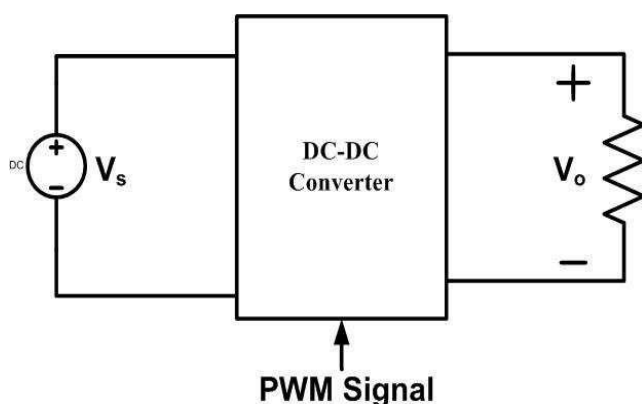

Fig. 1. Block Diagram of a DC-DC Converter

An electric power converter, DC-DC converter or more commonly known as a switched mode DC-DC converter as shown in Fig.1, either steps up or steps down the source

voltage, V_s according to the requirement of the load connected, by making adjustments in the duty cycle applied to the switching device (in most cases MOSFETs and IGBT's) [9].

In a DC-DC converter it is always desirable that a constant output voltage, V_o is achieved despite changes in the source voltage, V_s , the load current, i_{Load} and variations in element values of the converter circuit [10], [11]. These disturbances can be originated from second harmonic periodic variations of an off-line power system generated from the rectifier circuit and applied to the DC-DC converter, variation of the source voltage V_s due to switching (on/off) of neighboring power system loads and variations in the load current, i_{Load} amongst many. There are various types of DC-DC converters namely – Buck, Boost, Buck-Boost, Cuk, Sepic and Zeta. One of the most prominent research interests in this era is the application of DC-DC converters with high step-up voltage gain.

Several control techniques have been proposed to ensure stability as well as fast transient response namely - Fuzzy Logic controller, Artificial Neural Network (ANN), PID controller and PI controller. Several Optimization techniques such as Genetic Algorithm, Particle Swarm Optimization, and Bacterial Foraging Optimization have also been proposed [11], [12], [20], [21].

Amongst all converters, most widely used DC-DC converter is the Boost converter, a step up converter which provides a higher voltage at the load side, V_o compared to the source voltage V_s . Open loop mode of operation of Boost converter exhibits substandard voltage regulation and undesirable dynamic response. Therefore, closed loop mode of operation is preferred for proper voltage regulation and performance enhancement [13]-[19].

In this paper proper voltage regulation of Boost converter is achieved employing PID controller, tuned using trial and error method to find appropriate values for the proportional, integral and derivative gains, thereby improving converter performance. Section II of this paper deals with the conventional Boost converter followed by a brief idea about PID Controller in Section III, Section IV depicts the proposed converter and finally the simulation and results are presented by comparing the conventional Boost converter with the proposed or modified Boost converter with PID controller in section V. The proposed circuit parameters, simulation and experimental results demonstrate the effectiveness and feasibility of the proposed scheme.

II. Conventional Boost Converter

A conventional DC-DC Boost converter is composed of a boost inductor, two semiconductors (a diode and a transistor) and an output capacitor in parallel with the load as shown in Fig. 2.

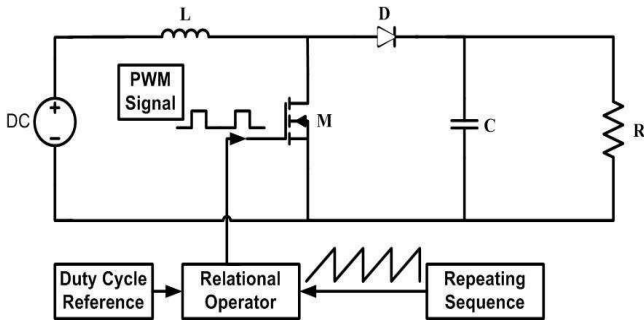

Fig. 2. Conventional Boost Converter

Boost converter also known as an up converter provides an output voltage that is greater than the input voltage. Input for a boost converter can be a simple DC source such as a battery, solar panel or can be obtained directly from an AC source through a rectifier. The inductors tendency to resist current variations due to changes in the magnetic field is the key principle that drives the Boost converter. Boost converter is said to operate in two modes. The switching is achieved using either a MOSFET or an IGBT. In low voltage applications MOSFET is preferred over IGBT due to its higher computational speed compared to IGBT. Modes of operation of Boost converter is as follows:

- o Mode 1 begins at $t = 0s$ when the transistor is switched on causing the rising input current to flow through the inductor L, storing energy in its magnetic field. During this mode of operation as shown in Fig. 3(a) the load side is completely isolated from the source side.
- o Mode 2 begins at $t = t_1$ when the transistor is switched off. Inductor, L produces a back emf having opposite polarity of the Mode 1 due to rapid drop in current. The voltage across the inductor and the source minus the small forward voltage drop across the diode, D charges the capacitor, C and also supplies the load. The conduction path is shown in Fig. 3(b).

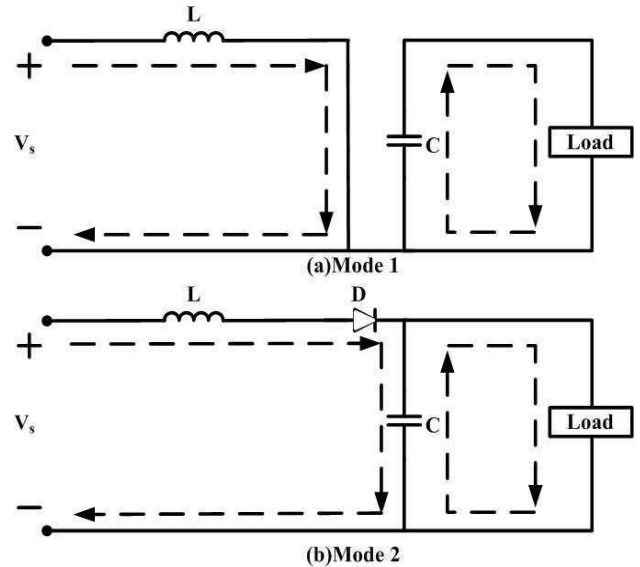

Fig. 3. Mode of operation of Boost Converter

The signal $e(t)$ as shown in Fig. 4 represents the tracking error obtained from the difference between the reference signal which serves as the input $R(t)$ and the actual output signal $V_O(t)$. The tracking error is fed on to the PID controller which computes the derivative and integral of the signal provided. The output of the PID controller $u(t)$ to be applied to the plant is equal to the proportional gain (K_P) times the magnitude of the error signal plus the integral gain (K_I) times the integral of the error signal plus the derivative gain (K_D) times the derivative of the error signal.

The plant on receiving the signal $u(t)$ will generate a modified output $V_O(t)$ which will be again compared to the reference signal until the desired level is reached thereby forming a close loop system. Effect of proportional, integral and derivative control on close loop system is summarized in the Table I. provided below.

Table 1. Effect of PID on close loop system

	Rise Time	Overshoot	Settling Time	Steady State Error
Proportional	Decrease	Increase	Small Change	Decrease
Integral	Decrease	Increase	Increase	Eliminate
Derivative	Small Change	Decrease	Decrease	Small Change

The controllers can be implemented individually as well as in combination, with the converters to obtain the desired result.

III. Proposed Converter

The proposed converter as shown in Fig. 6 is similar to the conventional Boost converter as shown in Fig. 2 but differs only in the incorporation of a PID controller which is extensively used in many practical applications for better performance. The proposed PID controller has been

obtained by block diagram reduction method in four stages as shown in Fig. 5. The first figure, Fig. 5(a) depicts a conventional PID controller block

One of the simplest and most widely used controller for decades is the PID controller. PID stands for proportional (P), integral (I) and derivative (D) controller. Fig. 4 shows the blockdiagram of a typical PID controller.

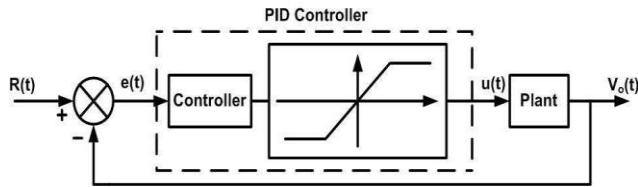

Fig. 4. Typical PID control Structure

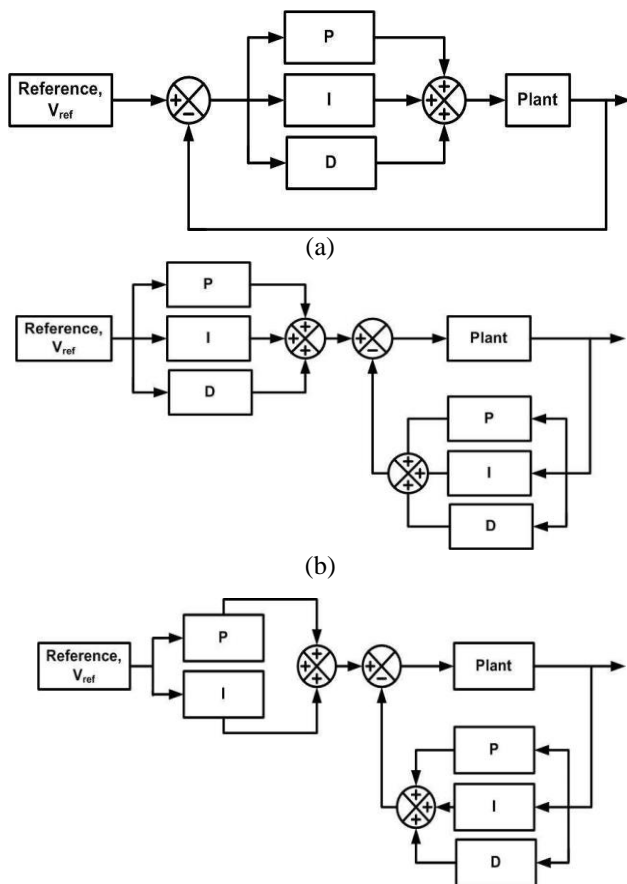

diagram when in successive stages as shown in Fig. 5(b), Fig. 5(c) by block diagram reduction technique the proposed control scheme for the Boost converter was obtained as shown in Fig. 5(d) which is feasible for proposed converter. Initial overshoot is a prime concern for Incorporating a PID controller with the converter improves the dynamic response and reduces the steady-state error. The derivative controller (KD) ameliorates the transient response and the integral controller (KI) will reduce the steady state error of the system. Our proposed system maintains an output of 200V when the input is in the range of 90V-110V which makes it quite feasible to apply in different industrial purposes.

IV. Result and Simulation

Simulation was done in MATLAB-Simulink environment. The parameters used for this simulation are given Table II. as shown below –

Table 2. Simulation parameters

Parameter	Value
Input Voltage	90V-110V
Output Voltage	200V
Rated Power	800W
Duty cycle	0.5
Boost Inductor	400µH
Filter Capacitor	100µ
Resistive Load	50Ω
KP	0.0033
KI	6.43
KD	0.0027

Conventional Boost converter as shown in Fig. 7, was simulated at 50% duty cycle and the output wave shapes observed for variations of input voltage from 90V – 110V with increment of 10V. It can be observed that the output voltage fluctuates with variation of input voltage by a large amount. Moreover the converter exhibits significant increase in overshoot as the input voltage varies as shown in Fig. 8.

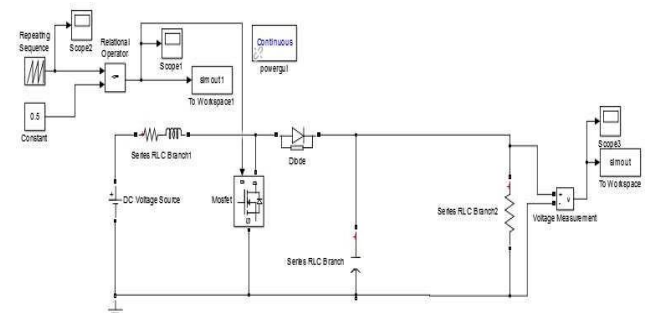
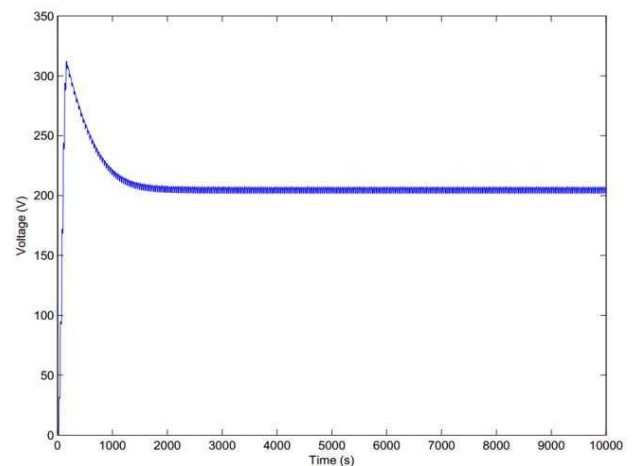
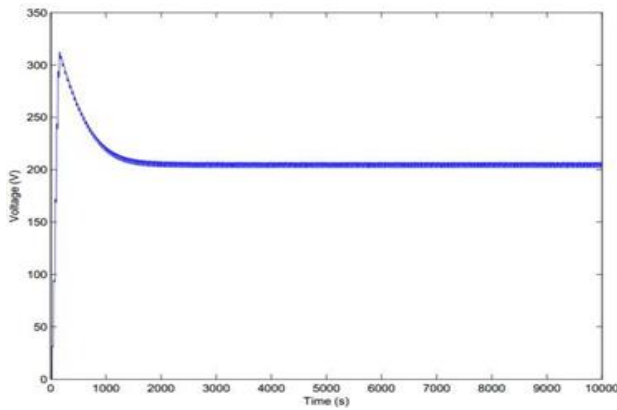

Fig. 7. MATLAB-Simulink model of conventional Boost converter



(a)



(b)

Fig. 8. Output voltage plot of conventional Boost converter operating at 50% duty cycle for input voltages (a) 90V, (b) 100V

Simulation data obtained as shown in Table III was plotted in MATLAB and comparison was done between conventional and proposed Boost converter in terms of output voltage as shown in Fig. 9 and percentage overshoot as shown in Fig. 10.

Table 3. Comparison between Conventional and Proposed Boost Converter

Input Voltage, V_i (V)	Conventional		Proposed	
	Output Voltage, V_o (V)	Percentage Overshoot (%)	Output Voltage, V_o (V)	Percentage Overshoot (%)
90	204.8	52.44	200.8	2.88
100	228.3	51.99	200.6	2.19
110	248.8	53.50	200.4	2.20

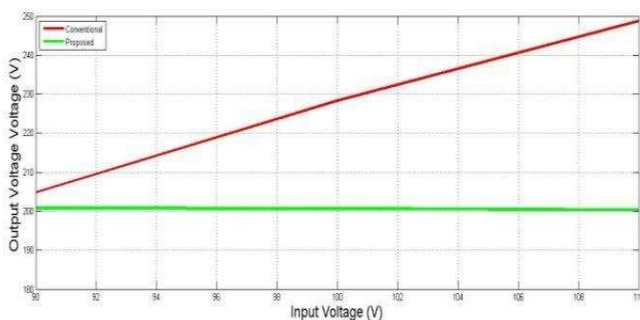

Fig. 9. Output voltage comparison between conventional and proposed Boost converter

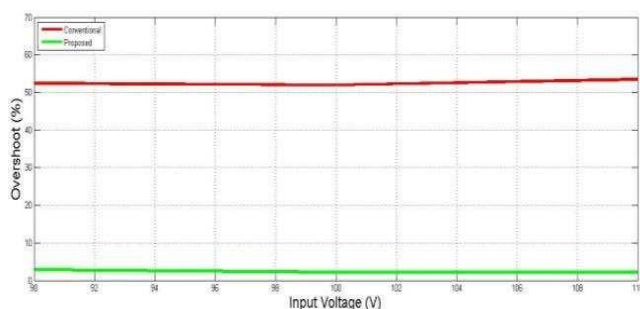

Fig. 10. Percentage overshoot comparison between conventional and proposed Boost converter

Experimental results show that the proposed PID controller when used with Boost converter provides better output voltage regulation and overshoot reduction, thereby improving the performance of the system.

V. Conclusion

The proposed Boost converters with PID controller provides better voltage regulation, overshoot reduction and improves the converter performance compared to the conventional Boost converter. This paper successfully provides a method to satisfy the objective of DC-DC converter to maintain a constant output voltage at the load side. The proposed circuit is simple, easy to understand and can be implemented with no additional components thereby keeping size and cost of manufacturing the converter within considerable range.

References

- [1] Kumar, J. Sai, and Tikeswar Gajpal. "A Multi Input DC-DC Converter for Renewable Energy Applications." (2016).
- [2] Ortiz, G., J. Biela, D. Bortis, and J. W. Kolar. "1 Megawatt, 20 kHz, isolated, bidirectional 12kV to 1.2 kV DC-DC converter for renewable energy applications." In Power Electronics Conference (IPEC), 2010 International, pp. 3212-3219. IEEE, 2010.
- [3] Wuhua, Xiaodong Lv, Yan Deng, Jun Liu, and Xiangning He. "A review of non-isolated high step-up DC/DC converters in renewable energy applications." In Applied Power Electronics Conference and Exposition, 2009. APEC 2009. Twenty-Fourth Annual IEEE, pp. 364-369. IEEE, 2009.
- [4] Koutroulis, Eftichios, and Kostas Kalaitzakis. "Design of a maximum power tracking system for wind-energy-conversion applications." IEEE transactions on industrial electronics 53, no. 2 (2006): 486-494.
- [5] Ferdous, S. M., Mohammad Abdul Moin Oninda, Golam Sarwar, Kazi Khairul Islam, and Md Ashraf Hoque. "Non-isolated single stage PFC based LED driver with THD minimization using Cúk converter." In Electrical and Computer Engineering (ICECE), 2016 9th International Conference on, pp. 471-474. IEEE, 2016.
- [6] Yang, Bo, Fred C. Lee, A. J. Zhang, and Guisong Huang. "LLC resonant converter for front end DC/DC conversion." In Applied Power Electronics Conference and Exposition, 2002. APEC 2002. Seventeenth Annual IEEE, vol. 2, pp. 1108-1112. IEEE, 2002.
- [7] Wei, Huai, and Issa Batarseh. "Comparison of basic converter topologies for power factor correction." In Southeastcon'98. Proceedings. IEEE, pp.348-353. IEEE, 1998.
- [8] Daniele, Matteo, Praveen K. Jain, and Geza Joos. "A single-stage power-factor-corrected AC/DC converter." IEEE Transactions on Power Electronics 14, no. 6 (1999): 1046-1055.
- [9] Rath, Ms Kashmira, and Dr MS Ali. "Design and Simulation of PID Controller for Power Electronics Converter Circuits." International Journal Of Innovative And Emerging Research In Engineering 3, no. 2 (2016): 26-31.
- [10] Dave, Mitulkumar R., and K. C. Dave. "Analysis of boost converter using pi control algorithms." International Journal of Engineering Trends and Technology 3.2 (2012): 71-73.
- [11] Raviraj, V. S. C., and Paresh C. Sen. "Comparative study of proportional-integral, sliding mode, and fuzzy logic controllers for power converters." IEEE Transactions on Industry Applications 33, no. 2(1997): 518-524.
- [12] Meena, Rajendra. "Simulation study of boost converter with various control techniques." International Journal of Science and Research (IJSR) 3, no. 9 (2014): 74-79.
- [13] W. Lu, S. Lang, L. Zhou, H. H. C. Iu and T. Fernando, "Improvement of Stability and Power Factor in PCM Controlled

- Boost PFC Converter With Hybrid Dynamic Compensation," in IEEE Transactions on Circuits and Systems I: Regular Papers, vol. 62, no. 1, pp. 320-328, Jan. 2015.
- [14] Z. Guo, X. Ren, Y. Wu, Z. Zhang and Q. Chen, "A novel simplified variable on-time method for CRM boost PFC converter," 2017 IEEE Applied Power Electronics Conference and Exposition (APEC), Tampa, FL, USA, 2017, pp. 1778-1784.
- [15] T. Meng; H. Ben; Y. Song, "Investigation and Implementation of a Starting and Voltage Spike Suppression Scheme for Three-Phase Isolated Full-Bridge Boost PFC Converter," in IEEE Transactions on Power Electronics, vol. PP, no. 99, pp. 1-1.
- [16] I. H. Kim and Y. I. Son, "Regulation of a DC/DC Boost Converter Under Parametric Uncertainty and Input Voltage Variation Using Nested Reduced-Order PI Observers," in IEEE Transactions on Industrial Electronics, vol. 64, no. 1, pp. 552-562, Jan. 2017.
- [17] J. Ma, M. Zhu, J. Zhang and X. Cai, "Improved asynchronous voltage regulation strategy of non-inverting Buck-Boost converter for renewable energy integration," 2015 IEEE 2nd International Future Energy Electronics Conference (IFEEC), Taipei, 2015, pp. 1-5.
- [18] A. Singh, A. A. Milani and B. Mirafzal, "Voltage regulation in single-stage boost inverter for stand-alone applications," 2014 IEEE Applied Power Electronics Conference and Exposition - APEC 2014, Fort Worth, TX, 2014, pp. 3011-3016.
- [19] O. Ibrahim, N. Z. Yahaya and N. Saad, "Comparative studies of PID controller tuning methods on a DC-DC boost converter," 2016 6th International Conference on Intelligent and Advanced Systems (ICIAS), Kuala Lumpur, 2016, pp. 1-5.
- [20] L. Mitra and N. Swain, "Closed loop control of solar powered boost converter with PID controller," 2014 IEEE International Conference on Power Electronics, Drives and Energy Systems (PEDES), Mumbai, 2014, pp. 1-5.
- [21] P. Verma, N. Patel, N. K. C. Nair and A. Sikander, "Design of PID controller using cuckoo search algorithm for buck-boost converter of LED driver circuit," 2016 IEEE 2nd Annual Southern Power Electronics Conference (SPEC), Auckland, 2016, pp. 1-4.