

High Step Up Three Phase AC-DC Converter with PWM and Switched Capacitor Technique

Puneet Kumar Shah^{1*}, K. T. Chaturvedi²

¹Department of Electrical Engineering, UIT-RGPV, Bhopal

²Department of Electrical Engineering, UIT-RGPV, Bhopal

Corresponding Author: punitkushah200@gmail.com

DOI: <https://doi.org/10.26438/ijcse/v7i5.14911495> | Available online at: www.ijcseonline.org

Accepted: 28/Apr/2019, Published: 31/May/2019

Abstract— A novel single stage high step up full bridge AC-DC converter, based on the concept of switched capacitor topology existing in high step up DC-DC converter, is proposed in this work. In switched capacitor technique, capacitors on secondary side are charged in parallel during the switch-off period, by the energy stored in the coupled inductor, and are discharged in series during the switch-on period to achieve a high step-up voltage gain. The switched capacitor technique meant for high voltage gain is discussed in many conventional DC-DC converters. The proposed AC-DC full bridge converter converts the input AC voltage into DC and boost with a high voltage gain in a single stage. For high voltage gain AC-DC converters many techniques are proposed in literature. In this work, switched capacitor technique is used in AC-DC converter is a novel method for attaining high voltage gain. Open loop control of the proposed converter is done by using PWM control. The closed-loop control methodology is utilized in the proposed scheme to overcome the voltage-drift problem of power source under the variation of loads. The operating principle, steady state analysis and design of proposed single stage high step up AC-DC converter is carried out. Simulation results, using MATLAB, are carried out for proposed AC-DC converter.

Keywords:- Full-bridge converters, Input current shaping, low-distortion input current, single-stage power factor correctors (PFCs)

I. INTRODUCTION

The present day automated world has witnessed inexplicable changes that have led to the growth and development of a contemporary technological era [1]. It has become imperative on the part of electric utilities to accommodate the necessary changes with a view to accomplish the challenges of the growing application needs [2, 3]. Thus the power electronic interfaces have become an imminent necessity in order to meet the objective. The consequent extensive use of semi-conductor power switches inadvertently generates the acrimonious signals. It may cause deleterious effects to the system as well as its performance. Today more than 70% of the electrical energy generated, flows through power electronic systems and it is expected that it will eventually grow to 100% [4, 5].

Three-phase AC-DC converters have a wide range of applications, from small converter to large high voltage direct current transmission systems. They are used for electrochemical processes, many kinds of motor drives, traction equipment, controlled power supplies and many other applications [6, 7]. From the point of view of the

commutation process, they can be classified into two important categories: line-commutated controlled converters and force-commutated pulse width modulated converters [8]. In most power electronic applications, the power input is in the form of a 50 or 60Hz sine wave ac voltage provided by the electric utility that is first converted to a dc voltage. Increasingly, the trend is to use the inexpensive rectifiers with diodes to convert the input ac into dc in a uncontrolled manner, using rectifiers with diodes as illustrated by the block diagram in Figure 1 [9, 10].

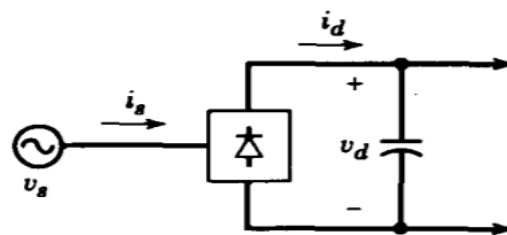

Figure 1: Block diagram of a rectifier

In such diode rectifiers, the power flow can only be from the utility ac side to the dc side [11]. A majority of the power electronics applications such as switching dc power supplies, ac motor drives, dc servo drives and so on, use

such uncontrolled rectifiers.

In most of these applications, the rectifiers are supplied directly from the utility source without a 50 Hz transformer. The avoidance of this costly and bulky 60 Hz transformer is important in most modern power electronic systems [12, 13].

The dc output voltage of a rectifier should be as ripple free as possible therefore, a large capacitor is connected as a filter on the dc side. This capacitor gets charged to a value close to the peak of the ac input voltage. As a consequence the current through the rectifier is very large near the peak of the 50Hz ac input voltage and it does not flow continuously; that is, it becomes zero for finite durations during each half-cycle of the line frequency [14]. These rectifiers draw highly distorted current from the utility. Now and even more so in the future, harmonic standards and guidelines will limit the amount of current distortion allowed into the utility, and simple diode rectifiers may not be allowed.

II. PULSE WIDTH MODULATION

PWM signals are pulse trains which are applied to the gate of switches to perform the operation of converter. The pulse trains are fixed frequency and magnitude and variable pulse width [15]. There is one beat of settled extent in each PWM period. In any case, the width of the beats changes from period to period as indicated by a regulating signal. At the point when a PWM flag is connected to the entryway of a power transistor, it causes the turn on and kills interims of the transistor to change starting with one PWM period then onto the next PWM period as indicated by the same regulating signal and thus working of converter begins. The recurrence of a PWM flag must be substantially higher than that of the regulating signal, the major recurrence, with the end goal that the vitality conveyed to the heap depends generally on the tweaking signal. The control of yield voltage is done utilizing beat width balance.

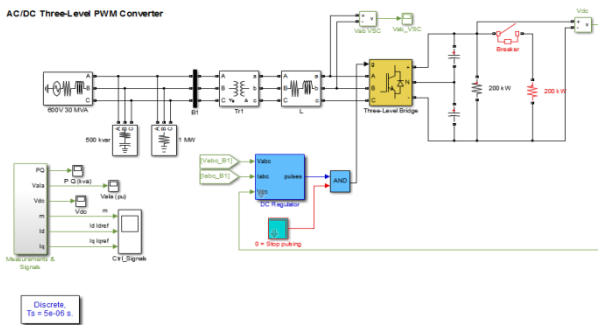

Figure 2: MATLAB Simulink Model of AC/DC Three Level PWM Converter

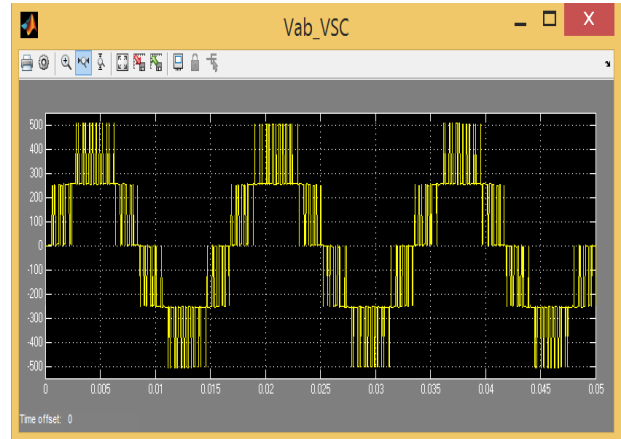

Figure 3: Output waveform of the AC/DC Three Level PWM Converter

VS dc bridge converter. With this technique sinusoidal input currents and ideally smoothed dc voltage may simultaneously be obtained, resulting in significant reduction of both ac and dc filters. Input power factor control is also achieved together with full regulation of the output voltage [16]. A simplified scheme using only three unidirectional switches is also studied, capable of similar performances in a reduced range of operation. The behavior of the converter is analyzed, even in non-ideal conditions, and design criteria are derived.

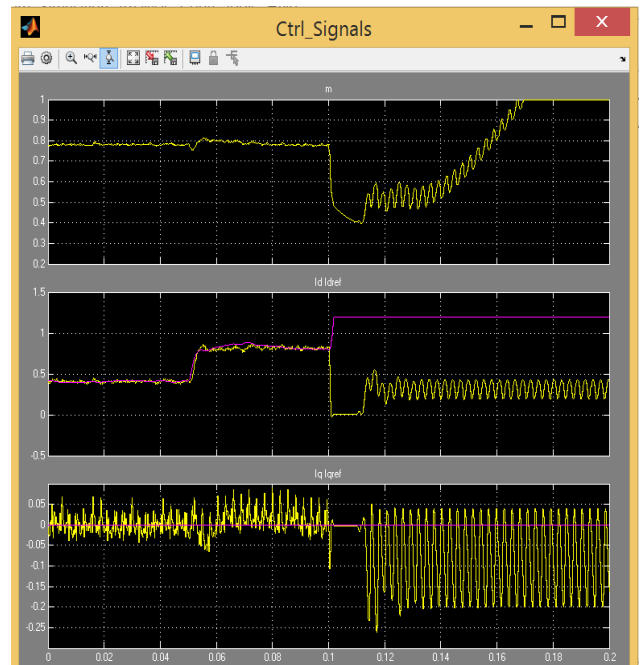
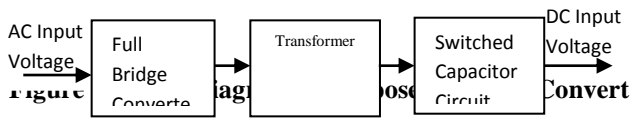

Figure 4: Output waveform of the AC/DC Three Level Control Signal PWM Converter

converters are intensity discharge lamp ballasts for automobile headlamps, fuel-cell energy conversion systems, solar-cell energy conversion systems, battery

backup systems for uninterruptible power supplies (UPS) etc. Here proposing a new single stage high step up AC-DC full bridge converter topology that features simple power and control circuitry. PWM control is used to control the switching action of the switches. Performance of the proposed converter under steady state analysis in continuous conduction mode is discussed in detail. Emphasis is given on demonstrating the operating principle, modes of operation, and derives circuit equation. The contents of this paper includes proposal of a new single stage high step up AC-DC full bridge converter topology that features simple power and control circuitry.

- 2) Full Bridge AC-DC converter (FB) which consists of four MOSFET switches that are built-in anti-parallel diodes
- 3) Performing the steady state analysis of the proposed converter in continuous mode of operation.
- 4) Analyzing the open loop and close loop simulation results of AC-DC full bridge converter.



The block diagram of AC-DC converter is shown in Figure 5, gives a constant ac input voltage to the MOSFET full bridge circuit, and that output is given to the primary side of the coupled inductor with low magnetizing inductance. The secondary side of the coupled inductor is fed to the switched capacitor circuit and obtains high voltage dc output voltage. Driver circuit is essential due for giving power to control signal for driving MOSFET.

IV. AC/DC CONVERTER USING SWITCHING TECHNIQUE

The circuit is composed of sinusoidal mains voltage V_{in} , four switches S1, S2, S3 and S4, coupled inductors N_p and N_s , diodes D_a , D_b , D_e , D_d , D_1 , D_2 , D_3 and D_4 , two capacitors C, and C2, two secondary diodes D5 and D6, output diode D_o , and output capacitor C_o and load R_o are shown in Figure 6. The turn's ratio of the coupled inductor n is equal to N_s/N_p .

However a known delay is introduced between turn-off of one switch and the tum on of the other switch of the same leg to avoid simultaneous conduction of any two switches from the same leg. The gate drives of both legs, S["]S4 or S2, S3 are complementary.

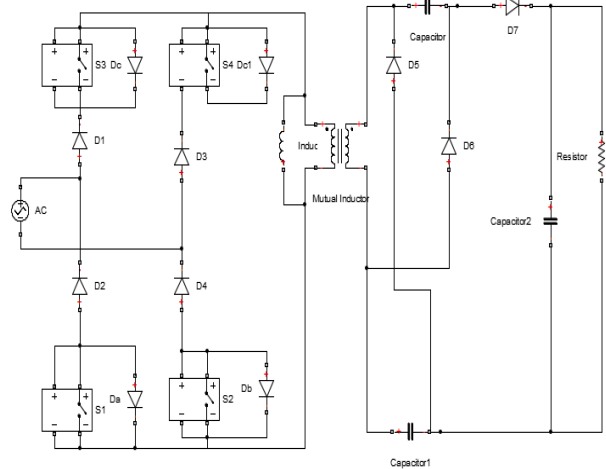

Figure 6: Circuit of Proposed Converter using Switching Capacitor Technique

The use of switches with low resistance RDS (ON) is to reduce the conduction loss of the entire circuit. The parallel charged current is not inflow. The proposed converter utilized the concept of switched-capacitor technique ie, two capacitors can be charged in parallel and discharged in series to achieve a high step-up gain. Thus, capacitors on the secondary sides C1 and C2 are charged in parallel and are discharged in series by the switches are turned OFF and turned ON is shown in Figure 4. Duty cycle D is defined as the time when S1 and S2 are both ON during the first half cycle or when S3 and S4 are both ON during the second half cycle.

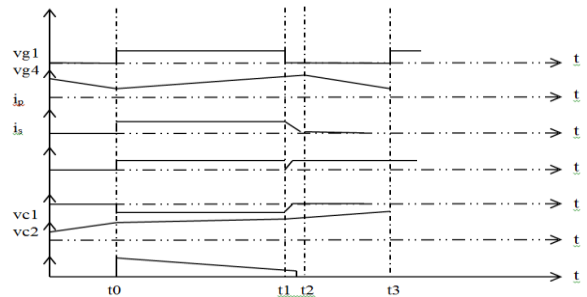

Figure 7: Waveforms of AC-DC Converter using Switching Technique

The principle is that, when the switches are turned ON, the energy stored in magnetic inductor and the coupled-inductor-induced voltage on the secondary and the induced voltage makes VL2, Vc" and VC2 release energy to the output in series. To achieve a high step-up voltage gain the proposed converter adds two capacitors and two diodes on the secondary side of the coupled inductor. The two capacitors can parallel charged by coupled inductor and series discharged. Figure 7 shows the waveform of the proposed AC-DC converter.

V. MODE OF OPERATION

This section presents three modes of operation of the proposed converter. Operation and the waveforms of the proposed AC-DC converter in positive half cycle and in negative half cycle are same. Only the difference is that in positive half cycle the two switches $S1$ and $S4$ are ON and the diodes $D1$ and $D4$ are in forward biased. But in negative half cycle the two switches $S2$ and $S3$ are ON and the diodes $D2$ and $D3$ are in forward biased. The modes of operation and the current flow path of each mode of the circuit in positive half cycle are discussed in this section.

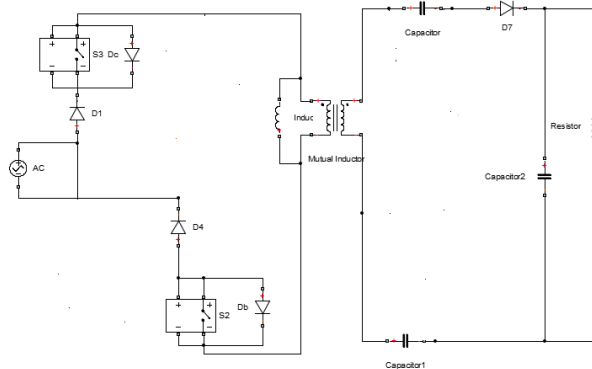

Figure 8: Circuit operation in mode-I

Mode 1: Figure 8 shows the mode I operation. Here the two switches $S1$ and $S4$ are ON. The magnetizing current i_{Lm} will increase linearly. The two secondary capacitors $C1$ and $C2$ are discharged in series. Diodes $D1$ and $D4$ and the output diode $D0$ will be in forward biased. The secondary diodes $D5$ and $D6$ will be in reverse biased. V_{in} , V_{C1} , V_{C2} which are connected in series, discharge to high-voltage output capacitor $C0$ and load R . This mode ends at the time $t=t_1$.

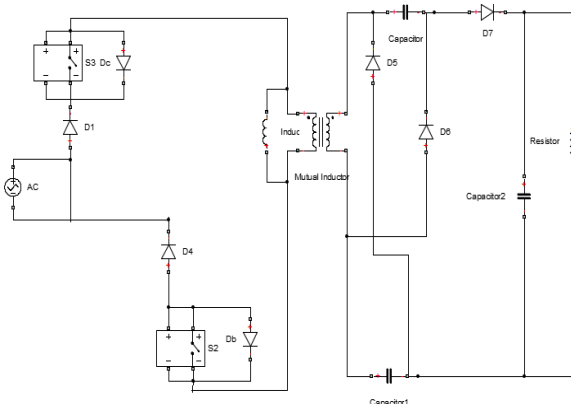

Figure 9: Circuit operation in mode-II

Mode II: mode II shows in Figure 9. Here $S1$ and $S4$ are in off condition and the input voltage pass through the parasitic capacitor. The energy of magnetizing inductor Lm transfers to capacitors $C1$ and $C2$ and charged in parallel.

The diodes $D1$, $D4$ and the secondary diodes $D5$ and $D6$ and output diode $D0$ will be forward biased the output capacitor $C0$ provides energy to the load R . This mode ends at the time $t=t_2$.

VI. CONCLUSION

In this paper, after the study of methods used to improve the voltage gain in DC-DC converter and AC-DC converters in the early literature, a new single stage AC-DC converter has been proposed based on the idea of switched capacitor technique, this paper proposes a novel single stage high step up full bridge AC-DC converter based on the concept of switched capacitor topology, implemented in high step up DC-DC converter. In switched capacitor technique, capacitors on secondary side are charged in parallel during the switch-OFF period, by the energy stored in the coupled inductor, and are discharged series during the switch-ON period to achieve a high step-up voltage gain. The proposed AC-DC full bridge converter converts the input AC voltage into DC and boost with a high voltage gain in single stage. For high voltage gain AC-DC converters many techniques are proposed in literature. In this work, switched capacitor technique is used in AC-DC converter is a novel method for attaining high voltage gain.

REFERENCE

- [1] K. C. Iseng and T. I. Liang, "Analysis of integrated boost-fly-back step up converter," *Processing Inst. Elect. Eng. Elect. Power Appl.*, vol. 152, no. 2, pp. 217- 225, Mar. 2005.
- [2] R. J. Wai and R. Y. Ouan, "High step-up converter with coupled inductor," *IEEE Trans. Power Electron.* vol. 20, no. 5, pp. 1025- 1035, Sep. 2005.
- [3] R. J. Wai, C. Y. Lin, C. Y. Lin, R. Y. Ouan, and Y. R. Chang, "High efficiency power conversion system for kilowatt-level stand-alone generation unit with low input voltage," *IEEE Trans. Ind. Electron.* vol. 55, no. 10, pp. 3702- 3714, Oct. 2008.
- [4] L. S. Yang, T. J. Liang, and J. F. Chen, "Transformer-less dc-dc converter with high voltage gain," *IEEE Trans. Ind. Electron.* vol. 56, no. 8, pp. 3144- 3152, Aug. 2009.
- [5] F. L. Luo, "Six self-lift dc-dc converters, voltage lift technique," *IEEE Trans. Ind. Electron.* vol. 48, no. 6, pp. 1268- 1272, Dec. 2001.
- [6] F. L. Luo and H. Ye, "Positive output super-lift converters," *IEEE Trans. Power Electron.* vol. 18, no. 1, pp. 105- 113, Jan. 2003.
- [7] T. F. Wu, Y. S. Lai, J. C. Hung, and Y. M. Chen, "Boost converter with coupled inductors and buck-boost type of active clamp," *IEEE Trans. Ind. Electron.* vol. 55, no. 1, pp. 154-162, Jan. 2008.
- [8] R. J. Wai and R. Y. Ouan, "High step-up converter with coupled inductor," *IEEE Trans. Power Electron.* vol. 20, no. 5, pp. 1025- 1035, Sep. 2005.
- [9] T. F. Wu, Y. S. Lai, J. C. Hung, and Y. M. Chen, "Boost converter with coupled inductors and buck-boost type of active clamp," *IEEE Trans. Ind. Electron.* vol. 55, no. 1, pp. 154-162, Jan. 2008.

- [10] D. C. Lee and D. S. Lim, "AC voltage and current sensor less control of three-phase PWM rectifiers," IEEE Trans. Power Electron., vol. 17, no. 6, pp. 883–890, Oct. 2002.
- [11] T. Jin et al., "A universal vector controller for three-phase PFC, APF, STATCOM, and grid-connected inverter," in Nineteenth Annual, Applied Power Electronics Conference and Exposition(APEC), IEEE, vol. 1. IEEE, 2004, pp. 594–600.
- [12] Revathi V I, Muhammedali Shafeeque K" Closed Loop Operation of High Boost OC-OC Converter Operating in CCM Mode" in Proc. International Journal of Scientific Engineering and Applied Science (USEAS) - vol. 1 , no.4, June 2015.
- [13] , "A novel primary-side regulation scheme for single-stage high-power-factor AC–DC LED driving circuit", IEEE Trans. Ind. Electron., vol. 60, no. 11, pp. 4979-4986, Nov. 2013.