

# Induction Motor's Health Diagnosis Based on Vibration Analysis

Viral R Avalani<sup>1\*</sup>, Takshak V Rabari<sup>2</sup>

<sup>1</sup>Electrical Engineering Department, Government Polytechnic-Rajkot, Gujarat, India

<sup>2</sup>Electrical Engineering Department, RCTI-Ahmedabad, Gujarat, India

Corresponding Author: [viralavalani@gmail.com](mailto:viralavalani@gmail.com),

DOI: <https://doi.org/10.26438/ijcse/v7i3.144148> | Available online at: [www.ijcseonline.org](http://www.ijcseonline.org)

Accepted: 05/Mar/2019, Published: 31/Mar/2019

**Abstract** – Induction motors are performing very critical roles in modern industries. Their reliable and efficient operation has great impact on performance of concerned industry. This work is intended to check feasibility for the use of micro electro mechanical accelerometers for the purpose of electric motor's vibration signature analysis. Here Lab-VIEW software is used for analysis and user interface. Vibration signal of motor is observed for various speeds and speed is changed by SPWM technique. The complete assembly of MEMS (Micro Electro Mechanical Systems) accelerometer ADXL 203 and interfacing devices (PCI 6221 and BNC 2120) is also verified with standard vibration signal generating laboratory equipments. This experimental work has confirmed the resemblance of electrical and mechanical fault in induction motors in terms of observable change in motor vibrations.

**Keywords** – Vibration signature, MEMS, “g” scale, FFT, Accelerometer.

## I. INTRODUCTION

In the modern day's industry, down time of machine is firmly linked with profitability of the organization. Analysis based on vibration signal generated by electric motors can deliver prior information of the probable sever fault at very initial stage. [1] This also helps as large machines are not required to be dismantled for the purpose of inspection. Continuous or periodic data of vibration recorded for the purpose of machine health inspection must be reliable and there has to minimum loss of data between signal of vibration generated by electric motor and the same acquired by transducers which is interfaced with Lab-VIEW in our case. The MEMS (Micro Electro Mechanical Systems) having transducer and signal conditioning elements fabricated on single chip will be helpful in transmitting vibration signal reliably. This work is an experiment with MEMS accelerometer to acquire vibration signal from the electric motor and check the reliability of the same.

## II. SIGNAL ACQUISITION

The FFT (Fast Fourier Transform) is used as mathematical tool for the purpose of analysis. A program developed in Lab-VIEW software will receive vibration signal acquired by ADXL 203 (MEMS accelerometer IC) through interfacing device PCI 6221. This interfacing card is acquiring data at speed of 250 KS/sec. Some of the external signals are interfaced and reliability of PCI-6221 is checked by following figures. Fig (1) show the rectangular signal and its FFT generated by Lab-VIEW program, and Fig (2) shows the sinusoidal signal, its FFT and assembly used for the external signal interfacing with computer.

## III. PROGRAM DEVELOPMENT

Objective of program is to perform FFT on the vibration signal acquired from electric motor and display magnitude of various frequency components present in the vibration signal. The program also includes standard patterns of vibration under various faulty conditions like misalignment, loose bearing, bent shafts, imbalance and electrical fault.

In vibration signature analysis the received signal is compared with reference data stored in program, this reference data provides threshold values for various frequency components which indicates presence of respective faults. This reference data may be provided by manufacturer of the machine can be obtained from standards like IS 11726, NEMA standards or can be derived through experiments.

Electrical fault and Mechanical fault can be segregated easily based on frequency bands, as most of electrical faults will have frequency components which are multiple of line frequency, and mechanical faults will have frequency components which are multiples of motor speed in Revolutions per Second. [1]

This program developed in Lab-VIEW is validated with standard signals, FFT of which are known, like rectangular and sinusoidal signal. The signal interfaced from signal generator and its FFT are as shown in fig (1) and fig (2). Fig (3) and fig (4) shows the flow chart of program.

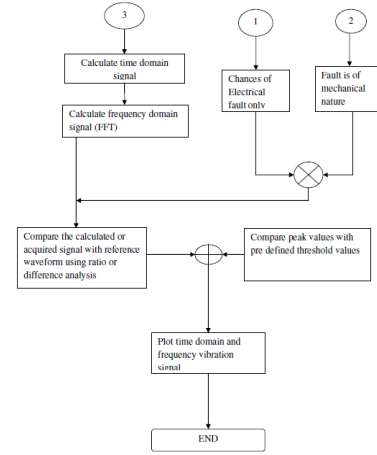
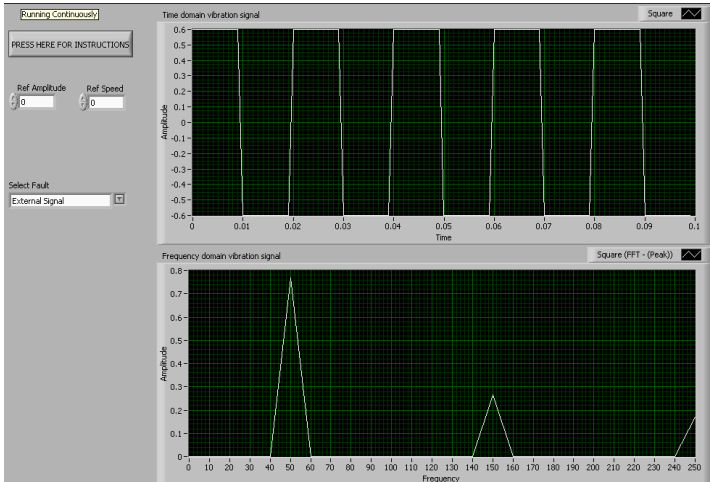

Fig.4 Flow chart for User Interface and fault calculation

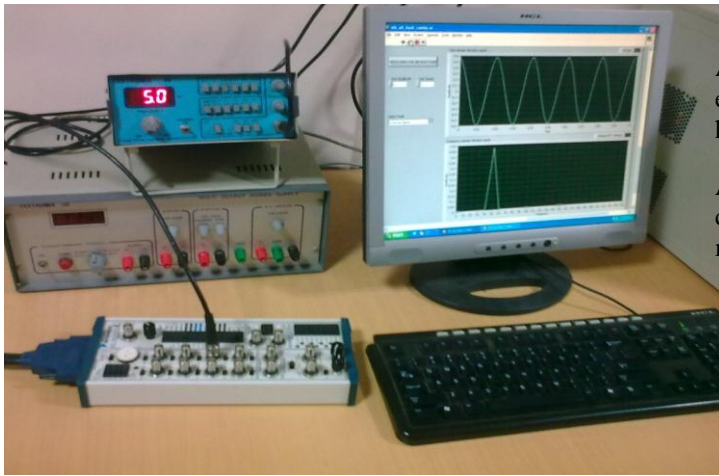

Fig.1 Rectangular waveform interfaced with PCI-6221

As shown in following figure (5), (6) and (7) user needs to enter running speed of motor in revolution per second and has to select type of fault to be simulated.

As shown below pure imbalance fault includes only one component that is twice the fundamental component of motor speed (2X). [2]

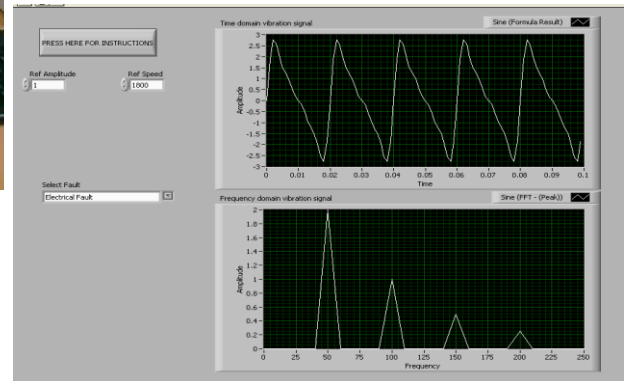
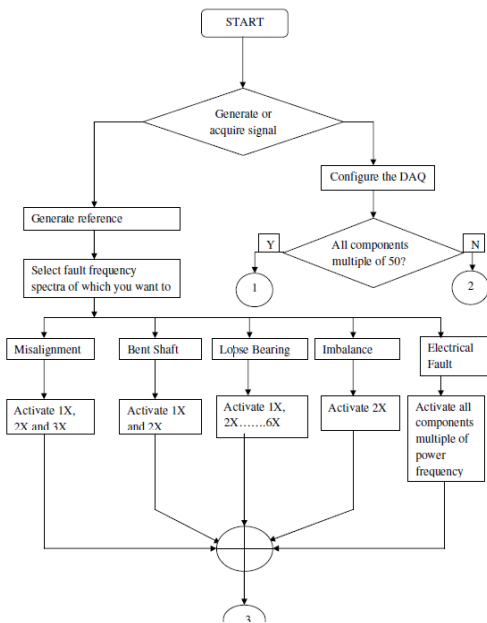

Fig.5 Electrical Fault

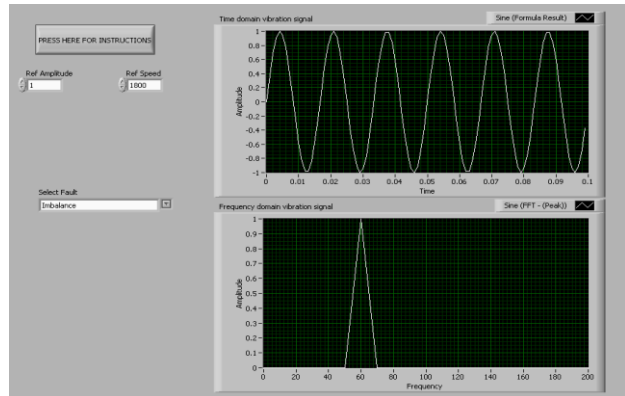

Fig. 6 Pure Imbalance

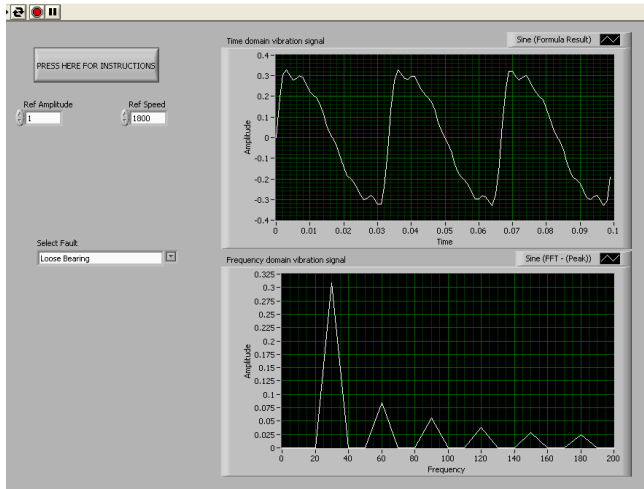

Fig.7 Loose Bearing

**IV. SELECTION OF IC**

Following parameters are taken in to account while selecting one chip accelerometer.

**Sensitivity constant:** It is measured in terms of mV/g, where “g” is the unit of acceleration. Now acceleration is depicted as multiple of gravitational constant (9.81 m/sec<sup>2</sup>).

**Frequency range:** This should be given by credit because frequency band of vibration signal with which selected accelerometer is going to work is not matched then, one cannot acquire the perfect pattern of vibration signal generated by motor. Most of the accelerometers have a flat response in the frequency range of 10-4000Hz. [3, 6]

**Amplitude linearity:** If magnitude of vibration signal is beyond or below certain value then output of accelerometer IC will not be proportional to the input vibration magnitude. The IC will lose its linearity and we will have incorrect value of vibrations. [3]

**Temperature linearity:** If transducer gets too cold or too hot its linearity falls of. IC accelerometers can work faithfully up to 250<sup>0</sup>F. [3]

Keeping all of above parameters in view ADXL 203 has been selected for this work. ADXL 203 is having sensitivity constant of 1000 mV/g, and can measure vibrations of at least ± 1.7g. It is having bandwidth of 2.5 KHz. [4]

C<sub>x</sub> and C<sub>y</sub> capacitances are connected externally to have flexibility in bandwidth ADXL 203.

$$BW = 1 / (2\pi \times 32K\Omega \times C) \text{ [5]}$$

Where C = C<sub>x</sub> = C<sub>y</sub>

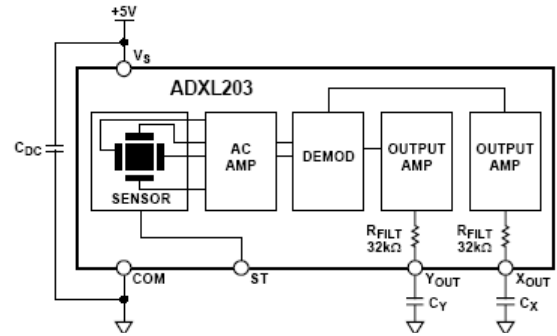

Fig. 8 Block diagram of ADXL 203[5]

The operation of IC accelerometers can be understood by fig (9). The IC accelerometer is mounted on body of motor, where maximum vibration is experienced. This vibration causes moving plates of accelerometer to displace, because of this displacement capacitance changes and output voltage changes proportional to vibration energy input.

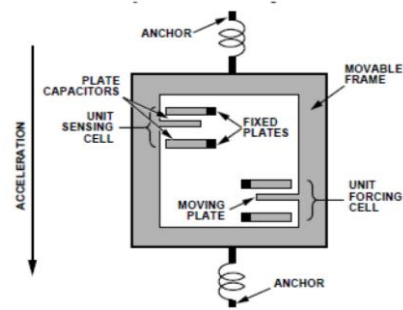

Fig. 9 Internal Arrangement in IC Accelerometer

**V. RESULTS ON FLEXIBLE CANTILEVER BEAM**

Here ADXL 203 is mounted on flexible cantilever beam. A magnet is also attached with this beam at various positions, i.e. near the hinge, at free end of the beam and change in vibration signal is observed. Following figures shows the arrangement and output for various positions of the magnet.

When magnet is connected near the hinged end, damping provided by weight of magnet is minimum, so vibration level is maximum and while it is connected at free end damping effect of magnet’s weight is maximum so vibration level is minimum.

One thing should be kept in mind that, when external signal is selected by used in window the data of speed and magnitude is not necessary.

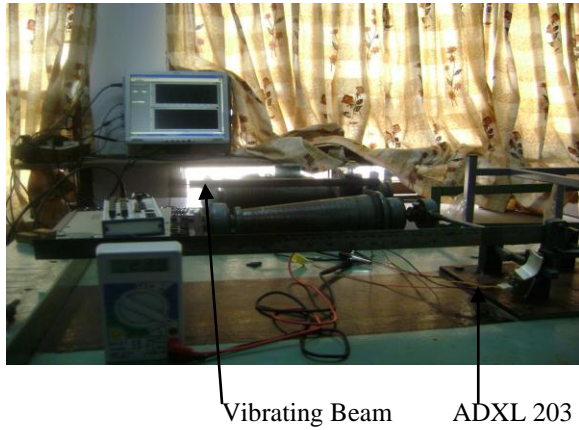

Fig. 10 Arrangement on Vibrating Beam

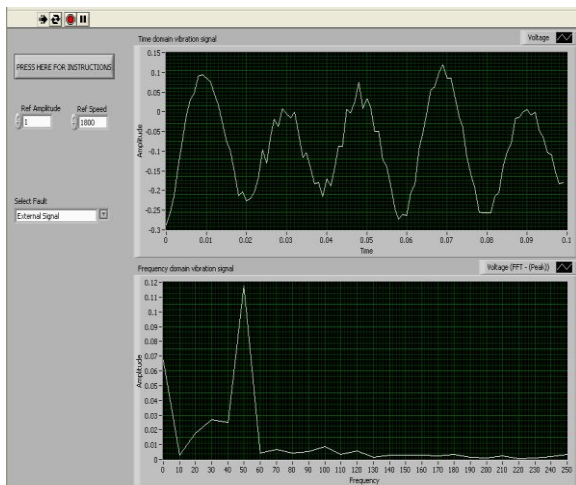

Fig. 11 Least vibration level (Magnet attached at free end)

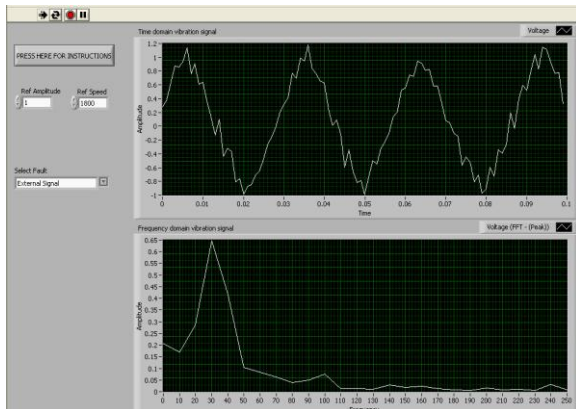

Fig. 12 Highest vibration Level (Magnet attached at hinge)

**VI. RESULTS ON INDUCTION MOTOR**

A Sinusoidal Pulse Width Modulated (SPWM) speed controlled 1440 RPM, 5 HP, 3- $\phi$  SCIM is equipped with

ADXL 203 - mounted on its terminal box. Here readings are taken at 50 Hz and 40 Hz frequency.

It can be seen from fig. (14) that, at 50 Hz frequency, all dominant components are multiple of 50 and at 40 Hz, dominant components are multiple of fundamental frequency of 40 Hz (fig 15).

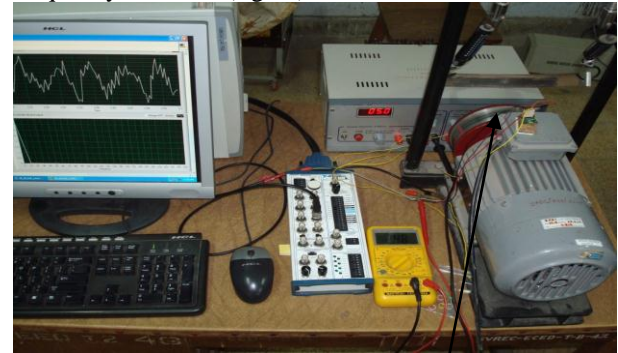

ADXL 203  
Fig. 13 Arrangement on SCIM

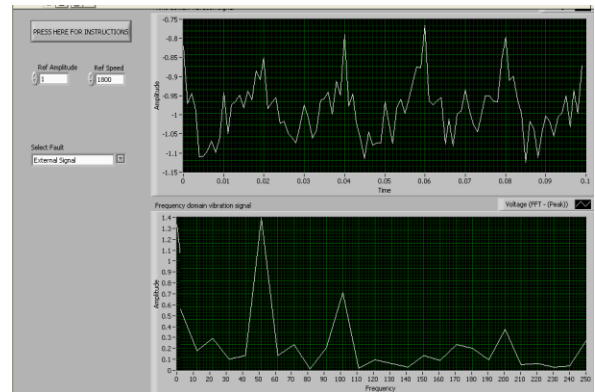

Fig. 14 SCIM Vibrations at MI=1 and f=50Hz

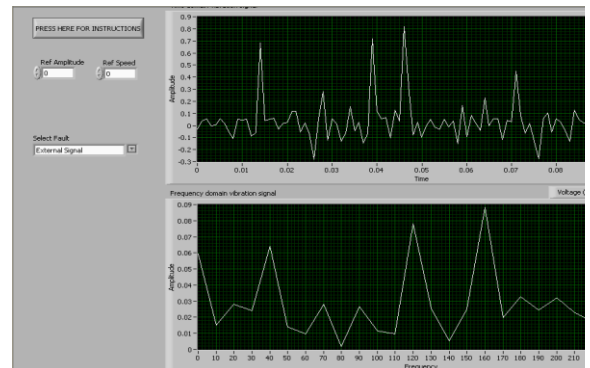

Fig. 15 SCIM Vibrations at MI=1 and f=40Hz

**VII. CONCLUSION**

With proper selection of instrumentation and program methodology vibration analysis can prove effective mean of

Induction Motor's health diagnosis. As in our case ADXL 203 IC accelerometer operates faithfully in its defined bandwidth of 2.5 KHz. As described in standards 1 KHz spectra and  $\pm 2g$  is extreme level of vibrations, ADXL 203 fits in to above mentioned criteria. Such IC accelerometers will lead to compact hand held vibration analyzing devices.

### REFERENCES

- [1] Steve Goldman, Vibration Spectra Analysis
- [2] R. Keith Mobley, Vibration Fundamentals
- [3] Vibration Analysis Handbook
- [4] ADXL 203 Datasheet
- [5] [www.analog.com](http://www.analog.com)
- [6] IS 11726

### Authors Profile

*Mr V. R AVALANI* pursued Bachelor of Engineering from VVP. Engineering college, Rajkot, INDIA. in 2006 and Master of Engineering from SVNIT, SURAT, INDIA in year 2009.. He is currently working as Lecturer, in Department of Electrical Engineering, Government Polytechnic Rajkot, INDIA. He has more than 8 years of teaching experience.



*Mr. T.V.Rabari* pursued Bachelor of Engineering from Gujarat University, INDIA. in 2002 and Master of Engineering from M.S. University, INDIA in year 2013.. He is currently working as Senior Lecturer, in Department of Electrical Engineering, at RCTI Ahmedabad, INDIA. He has more than 12 years of teaching experience.

