

# Review Paper on Hybrid Wind-Solar Energy System Renewable Energy Sources System

Pankaj Kumar Mahto<sup>1\*</sup>, Manish Kethoriya<sup>2</sup>

<sup>1,2</sup>Department of Electrical Engineering, SORT, People's University, Bhopal, India

DOI: <https://doi.org/10.26438/ijcse/v7i10.102106> | Available online at: [www.ijcseonline.org](http://www.ijcseonline.org)

Accepted: 08/Oct/2019, Published: 31/Oct/2019

**Abstract**— Now a day's electricity is most needed facility for the human being. All the conventional energy resources are depleting day by day. So we have to shift from conventional to non-conventional energy resources. In this the combination of two energy assets is happens i.e. wind and sunlight based energy. This procedure castigates the reasonable energy assets without harming the nature. We can give continuous power by utilizing half and half energy framework. Basically this system involves the integration of two energy system that will give continuous power. Sun based boards are utilized for changing over sunlight based energy and wind turbines are utilized for changing over breeze energy into power. This electrical power can use for different reason. Age of power will be happens at moderate cost. This paper manages the age of power by utilizing two sources consolidate which prompts produce power with moderate cost without harming the nature adjust.

**Keywords:** - Fuel cell, Photovoltaic, Wind energy conversion, Wind Turbines

## I. INTRODUCTION

Electricity is most needed for our day to day life. There are two methods for power age either by regular energy assets or by non-traditional energy assets. Electrical energy request increments in word so to satisfy request we need to produce electrical energy. Presently a day's electrical energy is created by the traditional energy assets like coal, diesel, and atomic and so on. The fundamental disadvantage of these sources is that it produces squander like fiery remains in coal control plant, atomic waste in atomic power plant and dealing with this wastage is expensive. What's more, it additionally harms he nature [1]. The atomic waste is extremely unsafe to individual too. The regular energy assets are draining step by step. Before long it will be totally vanishes from the earth so we need to discover another approach to create power. The new source ought to be dependable, contamination free and temperate. The non-ordinary energy assets ought to be great elective energy assets for the customary energy assets. There are numerous non-traditional energy assets like geothermal, tidal, wind; sun powered and so forth the tidal energy has downsides like it can just actualized on ocean shores [2]. While geothermal energy needs exceptionally ale venture to extricate warm from earth. Sun powered and wind are effortlessly accessible in all condition. The non-regular energy assets like sun oriented, wind can be great elective source. Sun based energy has downside that it couldn't deliver electrical energy in blustery and shady season so we have to beat this disadvantage we can utilize two energy assets with the goal that any of source comes up short other source will continue creating the power. Also, in great climate condition we can utilize the two sources consolidate [3, 4].

## II. HYBRID ENERGY SYSTEM

Hybrid energy system is the combination of two energy sources for giving power to the load. In other word it can characterized as "Energy framework which is manufactured or intended to separate power by utilizing two energy sources is called as the mixture energy framework." Hybrid energy framework has great unwavering quality, effectiveness, less discharge, and lower cost. In this proposed framework sunlight based and wind control is utilized for producing power. Sun powered and wind has great focal points than other than some other non-ordinary energy sources. Both the energy sources have more prominent accessibility in all territories. It needs bring down cost. There is no compelling reason to discover unique area to introduce this framework [5].

### A. Solar Energy

Solar energy is that energy which is gets by the radiation of the sun. Sun oriented energy is available on the earth ceaselessly and in plenteous way. Sun oriented energy is uninhibitedly accessible. It doesn't deliver any gases that mean it is without contamination. It is reasonable in taken a toll. It has low upkeep cost. Just issue with nearby planetary group it can't deliver energy in terrible climate condition. Be that as it may, it has more prominent productivity than other energy sources [6].

### B. Wind Energy

Wind energy is the energy which is extracted from wind. For extraction we use wind mill. It is renewable energy sources. The breeze energy needs less cost for age of power.

Support cost is likewise less for wind energy framework. Wind energy is available very nearly 24 hours of the day. It has fewer outflows. Beginning expense is likewise less of the framework. Age of power from wind is rely on the speed of wind streaming. The real impediments of utilizing free sustainable power source assets are that inaccessibility of energy forever. For conquering this we utilize sun oriented and wind energy together. With the goal that any one wellspring of energy falls flat other will deal with the age. In this proposed framework we can utilize the two sources join [7]. Another way is that we can utilize any one source and keep another source as a remain by unit. This will prompts congruity of age. This will make framework solid. The primary detriments of this framework are that it needs high introductory cost. But that it is dependable, it has fewer outflows. Kept up cost is less. Life expectancy of this framework is more. Proficiency is more. A principle preferred standpoint of this framework is that it gives constant power supply.

### III. DESIGN OF HYBRID ENERGY SYSTEM

For design of the hybrid energy system we need to find the data as follows

#### A. Data required for Solar System:

1. Annual mean daily duration of Sunshine hours
2. Daily Solar Radiation horizontal (KWH/m<sup>2</sup>/day)

#### B. Data required for Wind System:

1. Mean Annual Hourly Wind Speed (m/sec)
2. Wind Power that can be generated from the wind turbine

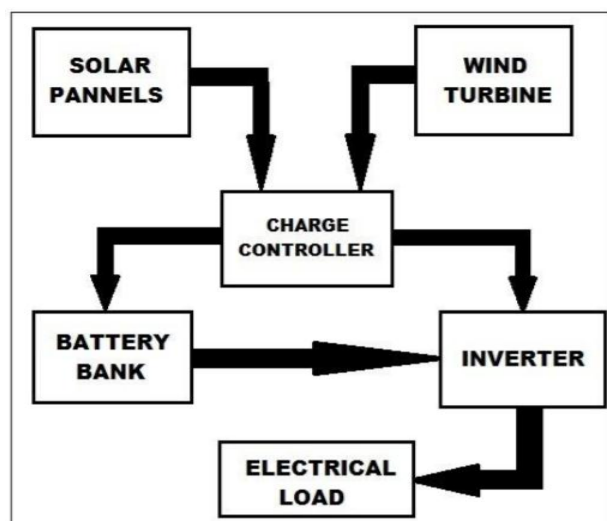

Figure 1: Block graph of Hybrid energy age framework

Above figure demonstrates the square outline of the cross breed control age framework utilizing wind and sunlight based power. This square outline incorporates following pieces.

- i. Solar panel
- ii. Wind turbine
- iii. Charge controller

#### (i) Solar panel

Solar panel is use to convert solar radiation to the electrical energy. The physical of PV cell is very similar to that of the classical diode with a PN intersection framed by semiconductor material. At the point when the intersection retains light, the energy of consumed photon is exchanged to the electron proton arrangement of the material, making charge bearers that are isolated at the intersection [8]. The charge bearers in the intersection area make a potential slope, get quickened under the electric field, and circle as present through an outer circuit. Sun powered exhibit or board is a gathering of a few modules electrically associated in arrangement parallel blend to produce the required current and voltage. Sun based boards are the medium to change over sun oriented power into the electrical power.

#### (ii) Wind turbine

Wind turbine is that framework which removes energy from twist by pivot of the sharp edges of the breeze turbine. Fundamentally wind turbine has two composes one is vertical and another is even. As the breeze speed builds control age is additionally increments. The power produced from wind isn't ceaseless its fluctuating. For acquire the non-fluctuating force we need to store in battery and after that give it to the heap.

#### (iii) Charge controller

Charge controller has basic function is that it control the source which is to be active or inactive. It all the while charge battery and furthermore offers energy to the heap. The controller has over-charge security, cut off, post perplexity assurance and programmed dump stack work. It additionally the capacity is that it ought to fluctuate the power according to the heap request. It include the both the power with the goal that the heap request can satisfy. Also, when control isn't producing it should remove control from battery and offer it to the heap.

### IV. CHARACTERISTIC OF PV SYSTEM

The photovoltaic cell converts the light energy into electrical energy depending on the irradiation of the sun and temperature in the atmosphere. Basically PVC is a PN junction diode [9, 10]. But in PN junction diode DCI AC source is needed to work, but here light energy is used as a source to produce DC output. PVC is a current control source not a voltage control source. The equivalent electrical circuit diagram of PVC is shown in the Figure 2.

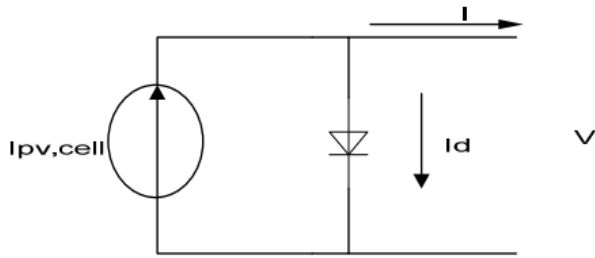

Figure 2: Show ideal photovoltaic cell equivalent circuit

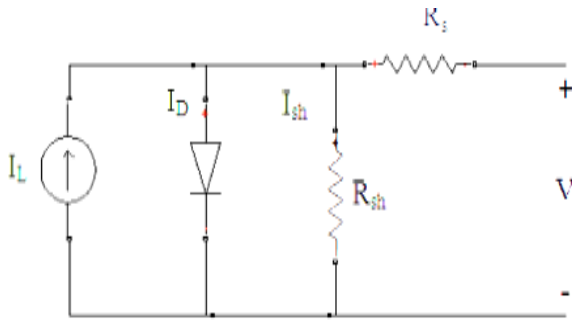

Figure 3: Equivalent Electrical Circuit of PVC

$$I_D = I_0[\exp(V + IR_s) / KT - 1] \quad (1)$$

Therefore PVC output current is given in equation 2.

$$I = I_L - I_D - I_{sh} \quad (2)$$

$$I = I_L - I_0[\exp(q(V + IR_s)) / KT - 1] - (V + IR_s) / R_{sh} \quad (3)$$

Where  $I_D$  the diode is current,  $R_{sh}$  is the shunt resistance,  $I_L$  is the light generated current of solar array. Sun based cell is fundamentally a p-n intersection created in a thin wafer or layer of semiconductor. The electromagnetic radiation of sunlight based energy can be specifically changed over power through photovoltaic impact. Being presented to the daylight, photons with energy more prominent than the band-hole energy of the semiconductor are consumed and make some electron-gap sets relative to the occurrence light. Affected by the inward electric fields of the p-n intersection, these bearers are cleared separated and make a photocurrent which is specifically relative to sun oriented insolation. PV framework normally displays a nonlinear I-V and P-V attributes which differ with the brilliant force and cell temperature [11].

### V. WIND ENERGY SYSTEMS

Wind energy has the biggest share in the renewable energy sector [1], [3]. Over the past 20 years, grid connected wind capacity has more than doubled and the cost of power generated from wind energy based systems has reduced to

one-sixth of the corresponding value in the early 1980s [3]. The important features associated with a wind energy conversion system are:

- Available wind energy
- Type of wind turbine employed
- Type of electric generator and power electronic circuitry employed for interfacing with the grid.

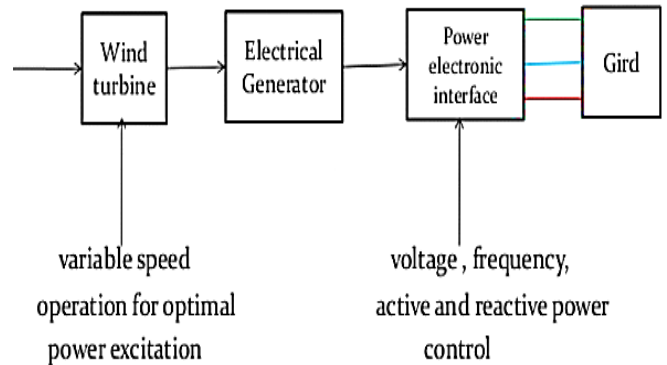

Figure 4: Variable speed wind energy conversion system

Wind energy – Wind speeds, pneumatic stress, climatic temperature, earth surface temperature and so forth, are exceptionally between connected parameters. Because of the characteristic multifaceted nature, it is improbable to expect a correct material science based expectation philosophy for wind power/supportability. Be that as it may, conveyance based models have been proposed, and utilized to anticipate the supportability of wind energy change frameworks [4]. Nitty gritty clarification of the breeze energy assets is past the extent of this paper. In light of studies it has been accounted for that the variety of the mean yield control from a 20 year time span to the following has a standard deviation of under 0.1 [12]. It can be closed with sensible certainty that breeze energy is a tried and true wellspring of clean energy. In light of the streamlined standard used, wind turbines are characterized into drag based and lift based turbines. In light of the mechanical structure, they are arranged into flat pivot and vertical hub wind turbines. As for the revolution of the rotor, wind turbines are ordered into settled speed and variable speed turbines. By and by the emphasis is on even pivot, lift based variable speed wind turbines. Power electronic circuits assume an essential empowering part in factor speed based breeze energy change frameworks. Settled speed wind turbines are easy to work, dependable and vigorous. However the speed of the rotor is settled by the network recurrence. As result, they can't take after the ideal streamlined proficiency point. If there should be an occurrence of differing wind speeds, settled speed wind turbines can't follow the ideal power extraction point. In factor speed wind turbines, control electronic hardware mostly or totally decouples the rotor mechanical recurrence from the lattice electrical recurrence, empowering the

variable speed activity. The sort of electric generator utilized and the lattice conditions manage the necessities of the power electronic (PE) interface. Fig. 1 portrays a variable speed wind energy change framework. The electrical generator famously employed for mostly variable speed wind energy transformation frameworks are doubly-nourished acceptance generators [5]. Fig. 5 portrays a doubly-sustained enlistment generator where the rotor circuit is controlled by the power converter framework by means of the slip rings and the stator circuit is associated with the matrix. This strategy is beneficial as the power converter needs to deal with a part ~ 25% - 50 % of the aggregate energy of the framework [5]. The power converter framework utilizes a rotor side air conditioning dc converter, a dc interface capacitor, and a dc-air conditioning inverter associated with the matrix as appeared in Fig.

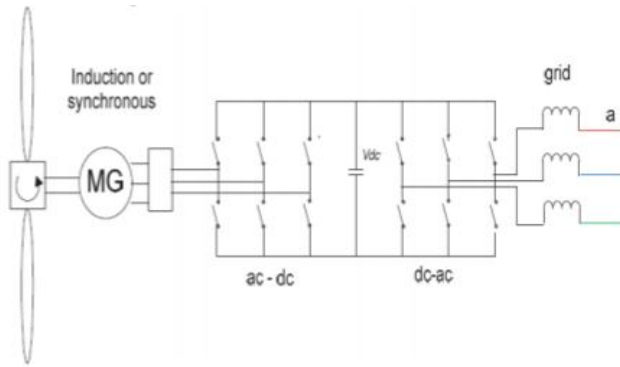

Figure 5: Fully variable wind energy conversion system

**VI. PROPOSED CALCULATION**

The total power generated by this system may be given as the addition of the power generated by the solar PV panel and power generated by the wind turbine. Mathematically it can be represented as,

$$P_T = N_w \times P_w + N_s \times P_s \tag{4}$$

Where,

- P<sub>T</sub> is the total power generated
- P<sub>w</sub> is the power generated by wind turbines
- P<sub>s</sub> is the power generated by solar panels
- N<sub>w</sub> is the no of wind turbine
- N<sub>s</sub> is the no of solar panels used

**A. Calculations for Wind Energy**

The power generated by wind energy is given by,

Power = (density of air \* swept area \* velocity cubed)/2

$$P_w = \frac{1}{2} \rho(A_w)(V)^3 \tag{5}$$

Where,

- P is power in watts (W)
- ρ is the air density in kilograms per cubic meter (kg/m<sup>3</sup>)
- A<sub>w</sub> is the swept area by air in square meters (m<sup>2</sup>)
- V is the wind speed in meters per second (m/s).

**B. Calculations for Solar Energy**

To determine the size of PV modules, the required energy consumption must be estimated. Therefore, the power is calculated as

$$P_s = I_{ns}(t) \times A_s \times Eff(pv) \tag{6}$$

Where, Ins (t) = isolation at time t (kw/ m2 )

A<sub>s</sub> = area of single PV panel (m2)

Eff(pv) = overall efficiency of the PV panels and dc/dc converters.

Overall efficiency is given by,

$$Eff(pv) = H \times PR \tag{7}$$

Where,

H = Annual average solar radiation on tilted panels.

PR = Performance ratio, coefficient for losses.

**VII. CONCLUSION**

Hybrid power generation system is good and effective solution for power generation than conventional energy resources. It has greater efficiency. It can provide to remote places where government is unable to reach. So that the power can be utilize where it generated so that it will reduce the transmission losses and cost. Cost reduction can be done by increasing the production of the equipment. People should motivate to use the non-conventional energy resources. It is highly safe for the environment as it doesn't produce any emission and harmful waste product like conventional energy resources. It is cost effective solution for generation. It only need initial investment. It has also long life span.

**REFERENCE**

- [1] Joanne Hui, Alireza Bakhshai, and Praveen K. Jain, "A Hybrid Wind-Solar Energy System: A New Rectifier Stage Topology," IEEE Conference, February 2010.
- [2] Trishan Efram, and Patrick L. Chapman, "Comparison of Photovoltaic Array Maximum Power Point Tracking Technique," IEEE Trans. on energy conversion, vol. 22, no. 2, june 2007.
- [3] [Cody A. Hill, Matthew Clayton Such, Dongmei Chen, Juan Gonzalez, and W.Mack Grady, "Battery Energy Storage for Enabling Integration of Distributed Solar Power Generation," IEEE Transactions on smart grid, vol. 3, no. 2, June 2012.
- [4] Hao Qian, Jianhui Zhang and Jih-Sheng Lai, "a grid-tie battery energy storage system," IEEE Conference, June 2010.
- [5] Sharad W. Mohod, and Mohan V. Aware, "Micro Wind Power Generator With Battery Energy Storage For Critical Load," IEEE systems journal, vol. 6, no. 1, march 2012

- [6] S.K. Kim, J.H. Jeon, C.H. Cho, J.B. Ahn, and S.H. Kwon, "Dynamic Modeling and Control of a Grid-Connected Hybrid Generation System with Versatile Power Transfer," IEEE Transactions on Industrial Electronics, vol. 55, pp. 1677-1688, April 2008.
- [7] Nabil A, Ahmed and Masafumi Miyatake, "A Stand – Alone Hybrid Generation System Combining Solar Photovoltaic and Wind Turbine with Simple Maximum Power Point Tracking Control," IEEE Conference, August 2006.
- [8] S. Jain, and V. Agarwal, "An Integrated Hybrid Power Supply for Distributed Generation Applications Fed by Nonconventional Energy Sources," IEEE Transactions on Energy Conversion, vol. 23, June 2008.
- [9] Matthew Clayton Such, Cody Hill, "Battery Energy Storage and Wind Energy Integrated into the Smart Grid," IEEE Conference, January 2012.
- [10] Hao Qian, Jianhui Zhang, Jih-Sheng (Jason) Lai, Wensong Yu, "A High-Efficiency Grid-Tie Battery Energy Storage System," IEEE transactions on power electronics, vol. 26, no. 3, march 2011
- [11] Niraj Garimella and Nirmal-Kumar C. Nair, "Assessment of Battery Energy Storage Systems for Small-Scale Renewable Energy Integration," IEEE Conference, January 2009.
- [12] Dezso Sera, Tamas Kerekes, Remus Teodorescu and Frede Blaabjerg, "Improved MPPT Algorithms for Rapidly Changing Environmental Conditions," IEEE Conference, September 2006.