

Sigma-Delta Controller for Speed Regulation of Interleaved Converter Fed PMDC Motor Drive

G. Rajalakshmi^{1*}, R. Ashok Kumar², K. Asokan³

¹ Department of Electrical Engineering, Annamalai University, Annamalai Nagar, India

² Department of Electrical Engineering, Annamalai University, Annamalai Nagar, India

³ Department of Electrical Engineering, Annamalai University, Annamalai Nagar, India

*Corresponding Author: rajiravi2014@gmail.com, Cel.: +91-8248925296

Available online at: www.ijcseonline.org

Accepted: 03/Jun/2018, Published: 30/Jun/2018

Abstract—The drive industry appears to invite a need for assuaging greater flexibility of its entities. Despite the astounding spurt in the control mechanism for operating the converter, it still requires and further enhancements to realize better performances of the drive system. The significant interest centers around an emphasis to address the switching effects on the output voltage ripple. The reduction in ripple can allow a better voltage or speed regulation of the drive motor power from chosen two stage dc-dc converter. The attempt envisages exploring the usage of a fresh sigma delta based pulse generation methodology for the power devices in the converter. It orients to evaluate its performance using MAT LAB simulation and exhibit its suitability in terms of its indices and characteristics of the drive motor for establishing its claim in the utility world.

Keywords— *Sigma-Delta controller, interleaved converter, PMDC Motor*

I. INTRODUCTION

Power electronic (PE) circuits have gone through a very fast technological advancement in the last four decades. Their applications are expanding from industrial, commercial and residential to even military environments [1]. They can usually fulfill many of the functional requirements successfully with high efficiency because of the minimum storage elements used. They being switched and periodically driven dynamical systems, multi-cell converters like other PE converters are also piecewise linear systems with discontinuous vector field able to present complex dynamics and requiring accurate modeling [2].

On the other hand, the research in topologies has evolved independently yielding new structures for new applications. For instance, new schemes of converters have been developed to overcome shortcomings in solid-state switching device ratings so that they can be applied to high-voltage electrical systems. Applications include such uses as medium voltage adjustable speed motor drives, dynamic voltage restoration and harmonic filtering. These converters [3-7] are also good candidates in power integration as they offer a natural dynamic filtering and thus the system size could be reduced.

Distributed power sources are expected to become increasingly prevalent in the near future. The use of such converters to control the current and voltage output directly

from renewable energy sources [8-10] will provide significant advantages because of their fast response and autonomous control. Additionally, they can also control the active and reactive power flow from a utility connected to renewable energy source. The nominal operation of the overall system is a limit cycle whose stability cannot be studied accurately by the traditional averaged model. This model was found to fail in predicting some nonlinear phenomena in power.

Multi converter power electronic systems are becoming increasingly common in applications [11-15] such as aircraft, spacecraft, hybrid electric vehicles, electric vehicles, defense electronic power systems, industrial production lines, communication, computer systems and many more, due to their advantages in weight, size, voltage regulation, flexibility, capability to integrate a large variety of loads and capability to control the quality of power [15].

A multi converter power system is a system where the power processing function is distributed among many power processing units like dc/dc converters, dc/ac inverters and ac/dc rectifiers at the point of need. In order to have higher efficiency and better system characteristics, power electronic converters and motor drive systems need to be tightly regulated. Power electronic converters, when tightly regulated, behave as constant power loads. So there is a definite need to regulate the output voltage of the converters

and the speed of the drive motor to improve the performance of the overall system.

II. PROBLEM FORMULATION

Interleaved boost converters are widely used in high power variable speed drives. During their operation sudden disturbances in both supply and load may occur. In drive operations, the speed of the drive motor should be regulated even under these disturbed conditions. To perform this, the action of the controller is the need of the hour. A controller plays a vital role in drive applications. Though there are varieties of controllers, each has its own merits and demerits. Choosing a controller for a particular application depends on the performance indices of the controller. The main objective of this paper is to build a Sigma-Delta controller along with PI controller in the feedback path to generate pulses for the power switches in the interleaved boost converter that powers the drive motor for regulating the speed.

III. PROPOSED APPROACH

Fig.1 shows the block diagram of interleaved boost converter fed PMDC motor drive system. The dc supply is given to the PMDC motor through the interleaved boost converter. The SDM controller in the feedback path generates the switching pulses for the power switches in the interleaved converter.

A boost converter is a power converter with an output DC voltage greater than its input DC voltage. The key principle that drives the boost converter is the tendency of an inductor to resist changes in current. When being charged it acts as a load and absorbs energy like a resistor and when being discharged it acts as an energy source like a battery. The voltage it produces during the discharge phase is related to the rate of change of current, and not to the original charging voltage, thus allowing different input and output voltages. The basic principle of a boost converter consists of 2 distinct states.

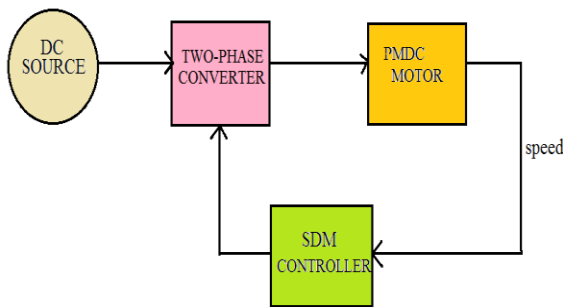

Figure 1.

Block diagram

- i. In the On-state, the switch S is closed, resulting in an increase in the inductor current and hence inductor charges.

- ii. In the Off-state, the switch S is open and the only path offered to inductor current is through the diode D, the capacitor C and the load R. These results in transferring of accumulated energy from supply and inductor to the capacitor.

IV. INTERLEAVED BOOST CONVERTER

The circuit diagram for the interleaved boost converter fed dc motor drive is shown in fig.2. The interleaving operation of two or more converters has been proposed to increase the output power and to reduce the output ripple.

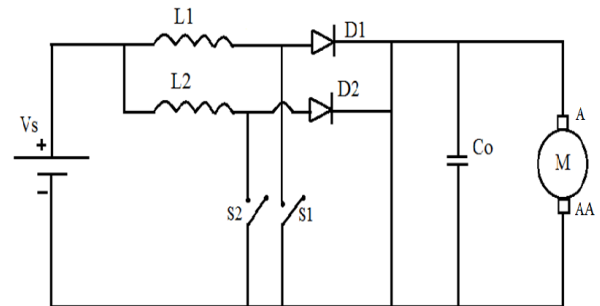

Figure 2. Power module

This technique consists of a phase shifting of the control signals of several cells in parallel operating at the same switching frequency. As a result the input and output waveform exhibit lower ripple amplitude.

A permanent magnet dc motor is powered from a dc source through dc-dc converter as shown in the same figure.

Modes of Operation:

Mode 1: In this mode the switch S1 is turned on, charging the inductor L1. The diode D1 is reverse biased and the current flows from supply through L2 and D2, enabling the discharge of the stored energy from the inductor L2 to the output capacitor Co and armature of the motor.

Mode 2: In this mode both switches S1 and S2 are turned off. The diodes D1 and D2 are forward biased, enabling the discharge of the energy stored in inductors L1 and L2 to the output capacitor Co and armature of the motor.

Mode 3: In this mode, the switch S2 is turned on, charging the inductor L2. The diode D2 is reverse biased and the current flows from supply through L1 and D1, enabling the discharge of the stored energy from the inductor L1 to the output capacitor Co and armature of the motor.

V. SDM AND PWM OPERATIONS

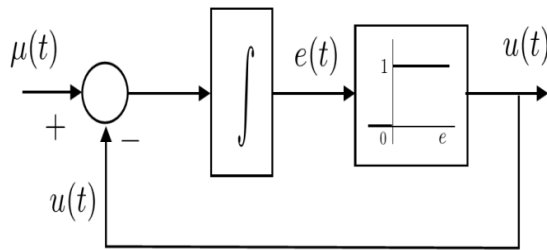

3.SDM Configuration

Sigma-Delta Modulation is widely used in communication systems. Even though they are in traditional with Communication system, in Power Electronics they are practiced recently. The SDM has been adapted to convert the analog signal to a digital signal (ADC) and digital to analog signal (DAC).The output of SDM changes between +1, 0,-1 according to the sampling period f_s which is greater than Nyquist-Rate. The SDM benefit is a feedback loop which decreases errors. So SDM can be used in order to control switches operation.

SDM which is implemented works as follows: First, the output voltage is compared with 24 V. The difference between 24 V and the output voltage is input of the PID controller. Output of the PID controller is $\mu(t)$ as shown in Fig.3. $\mu(t)$ is the input of SDM and $\mu(t)$ compared with $u(t)$ and it is composed of $e(t)$. $e(t)$ varies between -1,1 so one quantiser is needed to convert it into 0 or 1. A feedback from the output is compared with $\mu(t)$. It makes two pulse modes for switches.

The PWM switching works as follows: Output voltage is compared with 24 V DC as the reference output. The difference between these values is set as input of the PID controller. The output of the PID controller is the control value in PWM methods while a saw-tooth wave is a carrier.

VI. SIMULATION RESULTS

A 240V, 5HP, 1750 rpm dc motor is chosen for simulation. Fig.4 shows the waveforms for speed, armature current and electromagnetic torque for a load disturbance from no load to 2.5 KW at $t = 1$ sec. Since there is an increase load, a small dip in speed and corresponding increase in torque and current are realized. But because of the controller action the PWM pulse width is so adjusted to bring the speed to the regulated value of 1000 rpm.

Fig.4 shows the response of the controller for change in the reference speed command. Initially it is set at 1000 rpm and at $t = 1$ sec it is changed to 850 rpm. Further at $t = 1.5$ sec the command varied to 1500 rpm and finally at $t = 2$ sec it is given as 500 rpm. The blue line shows the reference speed command and green line shows the actual speed of the

motor. From the graph it is clearly understood the ability of the controller for the transient response.

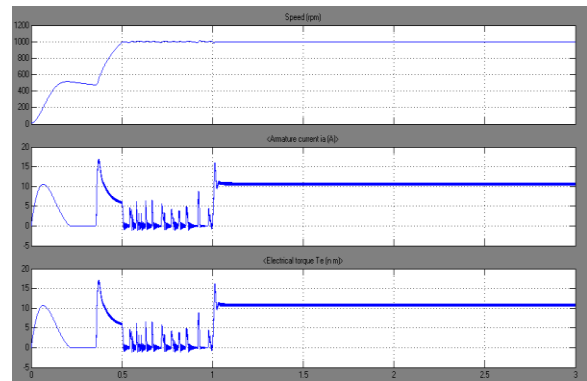

Figure 4. Waveforms of dc motor for load disturbance

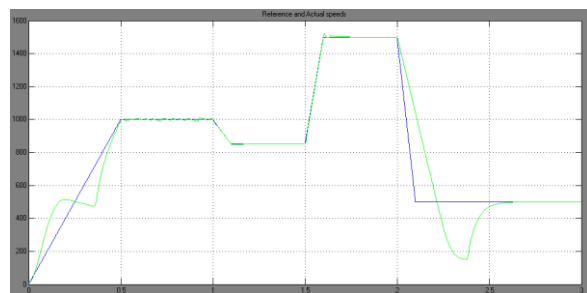

Figure 5. Waveform of actual speed versus motor speed

The comparative results for PI and SDM controller are presented in Table 1. From the table the superiority of the SDM controller over PI controller is proved.

Table 1. Performance Comparison

Load (KW)	Armature current (A)		Speed (rpm)	
	PI	SDM	PI	SDM
0.5	2.3	2.0	1000	1000
1.0	4.5	4.2	1000	1000
2.0	8.8	8.4	1000	1000
3.0	13	12.6	1000	1000
3.5	14.9	14.6	1000	1000

VII. CONCLUSION

A simulation model using MATLAB-SIMULINK is developed for the dc-dc converter under study. A closed loop Sigma-Delta control algorithm (SDM) has been suggested in the feedback path to regulate the speed of the PMDC motor drive. The simulation is performed in closed loop mode and the results displayed. The role of the SDM controller is

investigated to regulate the speed of the drive motor over a range of load variations. The regulating action has been still important even under load and speed disturbed states. The results have created significance for comparison and justification. The paper has claimed its suitability for several applications like adjustable speed drives etc.

REFERENCES

- [1] V. Grigore, J. Hatonen, J. Kyyra, and T. Suntio, "Dynamics of a buck converter with a constant power load," in Proc. IEEE 29th Annu. Power Electron. Spec. Conf., vol. 1, pp. 72–78, May 1998.
- [2] S. Hadavi, M.J.Sanjari, "A Novel Approach for Interleaved Buck Step-Down Converter Switching using the Sigma-Delta Method", Electrical Engineering Department, Amirkabir University of Technology, Tehran, Iran 2,3 Faculty of Electrical Engineering, University Teknologi Malaysia, Johor Bahru, Johor DarulTakzim, Malaysia.
- [3] Giorgio Spiazzi, *IEEE "Analysis of the Interleaved Isolated Boost Converter with Coupled Inductors"* VOL. 62, NO. 7, JULY 2015.
- [4] R. Saadi, M. Bahri, M.Y. Ayad, M. Becherif, O. Kraal, A. Abouboul. "Implementation and Dual Loop Control of Two Phases Interleaved Boost Converter for Fuel cell Applications" Department of Electrical Engineering MSE Laboratory, Mohamed khider University Biskra, Algeria.
- [5] Rafael Pena-Alzola, Peter Ksiazek and Martin Ordonez "Introducing State-Trajectory Control for the Synchronous Interleaved Boost Converter" Department of Electrical and Computer Engineering The University of British Columbia Vancouver Canada, BC V6T 1Z4.
- [6] Jul-Ki Seok, "Modeling and Control of the Average Input Current for Three-Phase Interleaved Boost Converters", 10.1109/TIA.2014.2365635, IEEE.
- [7] Yie-Tone Chen*, Wei-Cheng Lin and Ruey-Hsun Liang Department of Electrical Engineering, "An interleaved high step-up DC-DC converter with double boost paths", National Yunlin University of Science and Technology, Douliu City, Yunlin 64002, Taiwan.
- [8] M. Godoy Simões; C. L. Lute; A. N. Alsaleem, "Bidirectional Floating Interleaved Buck-Boost DC-DC Converter Applied to Residential PV Power System Center for Advanced Control of Energy and Power Systems" Colorado School of Mines Golden, USA.
- [9] Koki Ishikawa, Yohhei Mochizuki, Kohji Higuchi, Kamon Jirasereeamornkul, Kosin Chamnongthai, "Design of Approximate 2-Degree-of-Freedom Controller for Interleaved PFC Boost Converter", The University of Electro-Communications 1-5-1, Chofugaoka, Chofu, Tokyo, 182-8585, Japan.
- [10] Chong-Eun Kim, Deok-Ki Yang, Jae-Bum Lee, and Gun-Woo Moon, "High Efficiency Two Inductor PFC Boost Converter Employing SPDT Relay", Server Power Development Team, Samsung Electro-Mechanics, Suwon, Korea, 10.1109/TPEL.2014.2368567, IEEE.
- [11] Donny Radianto Student Member, *IEEE* Kyushu University, "Neural network based a two phase interleaved boost converter for photovoltaic system", Japan State Polytechnic of Malang, Indonesia, Milwakuue, USA 19-22 Oct 2014.
- [12] Laszlo Huber, Member, IEEE, Brian T. Irving, and Milan M. Jovanovic, "Fellow Open-Loop Control Methods for Interleaved DCM/CCM Boundary Boost PFC Converters", IEEE.
- [13] Boualem Salhia, Hassan El Fadilb, University of Mouloud Mammeri, Automatic Department, Tizi-Ouzou, "Adaptive Output Feedback Control of Interleaved Parallel Boost

Converters Associated with Fuel Cell", Algeria, Electric Power Components and Systems, 43(8–10):1141–1158, 2015.

- [14] Denis De Castro Pereira, Marico Renato Da Silva, Elder Mateus Silva and Fernando Lassa Tofoli, "Comprehensive review of high power factor ac-dc boost converters for PFC applications", CEP 36307-352 26 October 2014.
- [15] Miodrag Nikolić, Reinhard Enne, Bernhard Goll, Member, IEEE, and Horst Zimmermann, Senior Member, IEEE. A Nonlinear-Average-Current-Controlled Multi-Phase Boost Converter with Monolithically Integrated Control and Low-Side Power.

Authors Profile

G. Rajalakshmi received the B.E degree in Electrical and Electronics Engineering and the M.E degree in Power Systems from Annamalai University, Annamalai nagar, India in the year 2001 and 2008 respectively. She is currently pursuing her research program in the Department of Electrical Engineering and working as a Assistant Professor in the same department. Her areas of interest are Power Electronics and Drives, Analysis of Electrical machines, Electronic Devices and Circuits and Soft Computing Techniques.



R. Ashok Kumar is presently the Professor of Electrical Engineering, Annamalai University, India. His research interest includes Power system operation and control, Design analysis of Electrical Machines, Radial distributed system and deregulated power system studies. He has published many reports and journal articles in his research area. He received M.E degree (Power System Engineering) in 1999 and Ph.D degree in 2009 both from Annamalai University. In 1994 he joined Annamalai University as a Lecturer then elevated to the level of Professor. He is a member of ISTE and other technical bodies.



K. Asokan received the B.E degree in Electrical and Electronics Engineering in 2001, the M.E degree in Power system in 2008 and also awarded his Ph.D in Electrical Engineering in 2015 at Annamalai University, Annamalai nagar, Tamil nadu, India. Presently working as a Assistant Professor in the same department. His research interests include power system operation and control, Deregulated power systems, Hydrothermal Scheduling, Optimal Bidding Strategies and computational intelligence applications.

