

Review of Traffic Forecasting Approaches in Software Defined Mobile Networks

Anupriya^{1*}, Anita Singhrova²

^{1,2} CSE Department, DCRUST, Murthal, Sonapat, Haryana, India

Available online at: www.ijcseonline.org

Accepted: 19/Jun/2018, Published: 30/Jun/2018

Abstract- The use of mobile phones is increasing rapidly with varying traffic demand. This drastic increase in mobile traffic is due to video streaming, mobile TV, video conferencing etc. 4G network is unable to full fill this increasing demand of bandwidth, broader coverage and lower latency. Due to this ever increasing demand, next generation of mobile networks which uses SDN, NFV, cloud approach in mobile networks came into picture. This new generation could become more efficient if various forecasting approaches are used at the centralized controller. Various algorithms for forecasting 4G data already exists using predictable behavior of mobile data traffic. Work has already been done to deploy 5G which uses SDMN paradigm. Thereafter comes the need for some forecasting technique at SDMN controller, which could predict traffic and make decision according to that prediction at centralized controller. This paper presents existing work on traffic forecast, SDMN, traffic forecasting without SDMN and with SDMN. It also discusses data analysis for dataset collection on which traffic forecasting algorithms could be tested.

Keywords –Software Defined Network, Network Function Virtualization, Software Defined Mobile Network, Traffic Forecasting, Real time data

I. INTRODUCTION

Mobile data traffic has grown up to 18 times in last five years. As per prediction given by experts[1], monthly explosion in mobile data traffic will be 49 exabytes by 2021 [a sevenfold increase over 2016]. 4G mobile connections will go up from 2.1 billion in 2016 to 6.1 billion by 2021. 5G will be deployed in real world by 2020. 5G will come with various paradigms to enhance its functionalities[2]. SDN(software defined networking) technology is the integral part of 5G. This technology incorporate intelligence in the 5G networks. Intelligence means

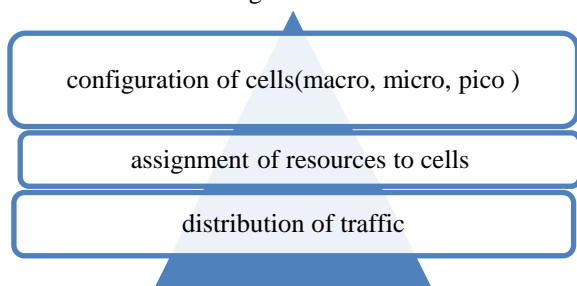

Fig 1: Inclusion of Intelligence in SDN

Mobile traffic forecasting in SDMN is required in order to make an intelligent network, which could automatically select the best resource allocation by studying the selected statistical parameters of previous traffic data itself. For

example in SDN, the data recorded at each base station is analyzed and traffic load is forecasted in long term and short term. Current mobile data traffic can follow any pattern like exponential, spatial, temporal. So an algorithm to take routing decisions at the SDN controller is needed, which can be implemented as an application in the mobile networks. Traffic forecasting is the necessity of today's time so as to reduce cost and improve profit of telecom industry by allocating resources dynamically as and when required. Large amount of energy consumption and spectrum usage results in need of more efficient planning of network and its operations. Due to non uniformity of mobile data traffic in time and space, it is not easy to make different designs. Short-term forecasting methods which give same information all the time for same kind of situation are increasing day by day. These methods are perfect for dynamically changing networks. Most important challenge is to provide appropriate performance to its users in situations of heavy traffic. In order to fulfill this requirement an accurate method of traffic forecasting is required. However, various existing traffic forecasting methods are very complex which makes the forecasting process slow and costly.

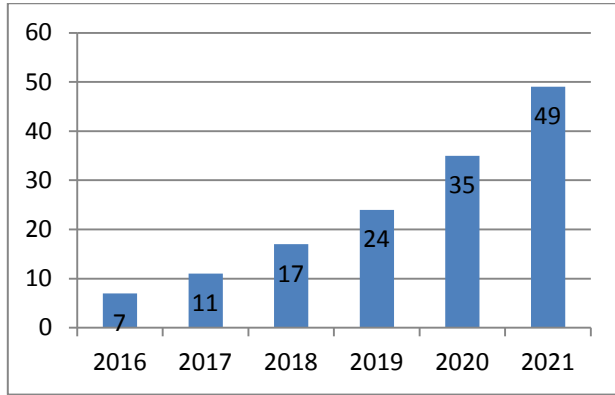

Fig 2: Data Traffic(Global) By 2021, Data Traffic in Exabytes [1]

1.1 Need Of Traffic Forecasting

With the increase in number of users, there comes the need to accurately utilize the available network and give quality services to its users at minimum cost. Accurate capacity measurement and planning of network is required to support burst in traffic. If resources are allocated statistically then a lot of expensive resources will go waste during low traffic hours and there will be a congestion in high traffic areas. Hence real time prediction of traffic is required for managing network in cost effective manner. The rest of paper is sectioned as given. Section 2 describes recent work on traffic forecasting. Section 3 presents an overview about datasets and the methodology already adopted for forecasting. Section 4 explains various existing algorithmic approaches for traffic forecasting without SDMN in detail, whereas traffic forecasting techniques in SDMN are discussed in section 5. Concluding remarks are given in section 6.

II. WORK RELATED TO TRAFFIC FORECASTING

The characterization and modeling of large scale traffic in mobile networks is presented in [4]. In [5] the author evaluated the smart phone performance for real time prediction of network traffic. Here a prediction algorithm is run on central server to obtain future state for the subset of the links in the networks that is referred to as compressed network state. The work in [6] measures the quality of experience in cellular networks i.e. the amount of bandwidth which is needed for popular smartphone applications and increasing demand of this bandwidth due to increase in mobile data traffic. The author reports on [7] shows the prediction of various traffic parameters and use data mining to analyze huge amounts of data as a preferred tool. It considers the density, speed and individual number of traffic flow. It uses fuzzy clustering analysis method. Author also points majorly on an expert system based on artificial neural networks. Its basic functioning depends

upon the inputs provided by reputed optimization engineers from the company Ingénue Telecom, S.L.

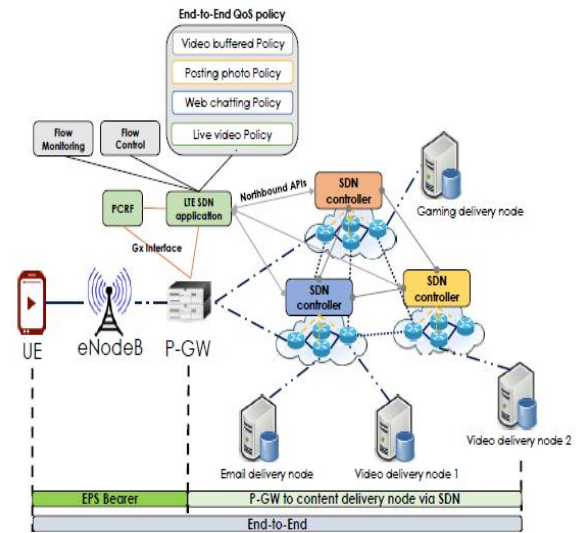

Fig 3 : Deployment of the Mobile Traffic Routing System in SDMN

III. SDMN Traffic Forecasting Process

3.1. Data Collection

Dataset for predictive work may be provided by a Indian Cellular company which include working data having data bursts on hourly basis from BSs of some city. Based on this data throughput is measured. These dataset usually have behavior of chaotic time series. The mobile network traffic data is collected by considering SDMN network model. This model is a realistic model by considering various parameters from the data collected from the routers of RIP or OSPF etc. These parameters are namely, performance criteria, number of hops, cost, delay, throughput. Based on these parameters, a model is prepared (using a simulation tool like Matlab) to get a realistic data model.

Table 1: Summary of procedure adopted for datasets collection using topology

Capturing Of Mobile Data	Using SDMN Mobile Network Topology from RIP or OSPF routers.
Data Description	To collect data bursts and compare with existing pattern matching algorithms.
Methodology Adopted	Apply a modeling technique to the data collected in previous step.

Traffic model first captures traffic data bursts for a long time without any stoppage. Now the data is compared with original data traffic model by using various pattern matching algorithms which are currently existing.

3.2 Data Cleaning

The faults in the traffic logging system results in missing values or negative values in the original dataset. The traffic data of those BS is neglected which have fault data points.

3.3 Data Analysis

Using real data, the key characteristics of data in cellular networks are selected, as well as their correlation with call hotspots takes place. Here, per-cell data usage is analyzed and data traffic over a period of time for all the users in each single cell is collected. Various characters which were taken into account can be Flow sizes, Temporal characteristics, Spatial characteristics

3.4 Prediction Model

This Step focus on creation of cellular traffic prediction model, the prediction manage to perform a classification to forecast a possible congestion of the system in the near future to make the system aware of congestion. This modeling process consists of multiple stages starting with

the calculation of different statistical features. These calculated features are not be specific to the field of traffic prediction but a wide variety of different measures have been taken that help reveal the dynamics of the system by deriving new information from the measured values. At this point the goal is to define as many number of calculated features as possible to provide enough information for the next stages of the method.

IV. MODELING TECHNIQUES

Modeling is a process which uses real time historical data and predict forecast outcomes. These models have a number of predictor variables which are responsible for future results. When data for relevant predictor is gathered, a model is formulated. Modeling techniques are used by various business analysts to solve critical and tricky problems like traffic routing problem. In this paper, various existing algorithms for traffic forecasting are presented. These algorithms are for traffic prediction in LTE networks. The details of various modeling techniques are shown in table 2.

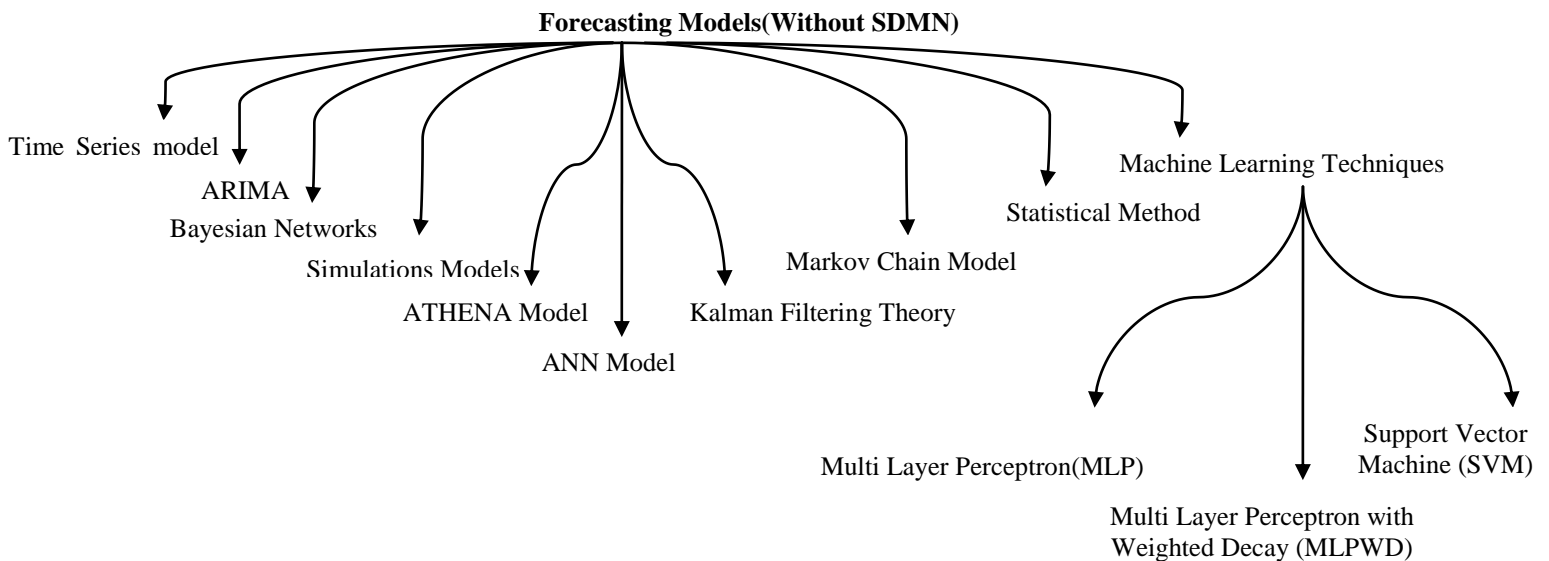

Fig 4 :Classification Of Modeling Techniques For Forecasting

Table 2: Comparative analysis of existing models of forecasting

SNo.	Title	Method	Advantages	Disadvantages
1.	A bayesian network approach to traffic flow forecasting. [8]	Bayesian Network	<ul style="list-style-type: none"> • Ability to create a Bayesian structure for the traffic flow on a given link in a given time. • Ability to cope with incomplete data. • Very good experimental results. 	Not an optimal approach for detecting abnormality like incidents and accidents.
2.	Traffic forecast using simulations of large scale networks[9]	Simulation Model	<ul style="list-style-type: none"> • Real world data can be incorporated using online simulation model. • These are done in real time and based on microscopic traffic flow. 	This model needs theories that have high predictive power which may take years to develop.
3.	An object-oriented neural network approach to short-term traffic forecasting[10]	Neural Networks	<ul style="list-style-type: none"> • Used for non-linear data traffic. • Uses a dynamic neural network architecture. • Uses object oriented approach so as to model complex network with a mixture of learning rules and processing element interactions. 	<ul style="list-style-type: none"> • Forecasting accuracy is not improved by enhancing the no of input sources. • Selection of input parameters is difficult.
4.	Neural network multitask learning for traffic flow forecasting[11]	Multitask Learning Based Network Model	<ul style="list-style-type: none"> • Improves the generalization of the network, thus increases forecast accuracy. 	Unable to prevent negative data transfer as data is trained without considering quality of predictors.
5.	Application of subset autoregressive integrated moving average model for short-term freeway traffic volume forecasting[12]	ARIMA(Auto-Regressive Integrated Moving Average) Model	<ul style="list-style-type: none"> • A statistical time series model which uses past trained data by using mathematical models and after that this model is employed for forecasting. • Better for predicting throughput on weekdays rather than weekends in a whole region. 	<ul style="list-style-type: none"> • Assumes data to be linear. • Not suited if information is missing and data filling techniques is problematic as situation becomes complex.

6.	The Holt-Winters Approach to Exponential Smoothing[13]	Exponential Smoothing	<ul style="list-style-type: none"> • An appropriate model to produce a smooth Time Series. • In Single-Moving-Averages model various past observations are weighted equally whereas Exponential Smoothing assigns exponentially decreasing weight as the observation get older. • The exponential-smoothing model is better than the ARIMA model for predicting throughput on weekends in a whole region and also it is best model for throughput in the single cell. 	Not an efficient model for throughput prediction on weekdays in whole region. ARIMA model works better in such cases.
7.	Traffic-flow forecasting using a 3-stage model[14]	KARIMA	<ul style="list-style-type: none"> • Uses self organizing maps. • Task separation feature improves forecasting accuracy and performs much better than ARIMA and NN. 	<ul style="list-style-type: none"> • Not long term robustness. • As conditions alternate, its performance will deteriorate.
8.	A Review of Network Traffic Analysis and Prediction Techniques[15]	LSSVM (least square based support vector machine)	<ul style="list-style-type: none"> • Good for dealing with non linear systems and for small sample size. • Widely used in face recognition, speech recognition (a good example of chaotic time series) 	<ul style="list-style-type: none"> • Cannot be used for large data size of nearly an year or more.
9.	Mobile Network Traffic Prediction Using MLP, MLPWD, and SVM[16]	MLP(Multi-Layer-Perceptron)	<ul style="list-style-type: none"> • Used for problems of supervised learning. • The model is evaluated and tested using training and testing datasets. • MLP create its regression model using ERM approach. 	Not suitable for predicting the multidimensionality of real time network data traffic.
10.	Mobile Network Traffic Prediction Using MLP, MLPWD, and SVM[16]	MLPWD(Multi-Layer-Perceptron -with-Weight-Decay)	<ul style="list-style-type: none"> • One-dimensional data is predicted accurately using this model. • Minimizes the risk on the prediction accuracy in networks such as neural networks. 	Not suitable for prediction of multidimensional data traffic. In this type of data, SVM outperforms this method.

V. TRAFFIC FORECASTING TECHNIQUES IN SDMN(SOFTWARE DEFINED MOBILE NETWORKS)

The existing algorithms for traffic forecasting which are specifically implemented at SDMN controller are considered and summarized in table 2.

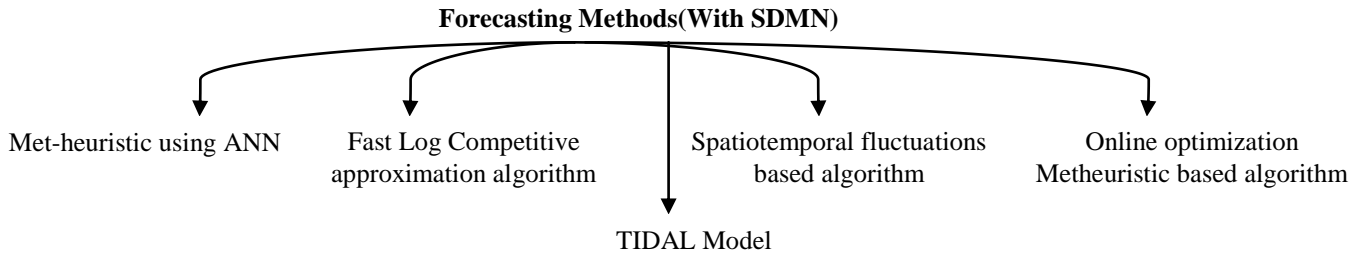

Fig 5 :Classification Of Modeling Techniques For Forecasting with SDMN

TABLE 3: Traffic Forecasting Techniques using SDMN

YEAR	TITLE	AUTHOR	JOURNAL/Conference	Salient Features	Limitations
2017	Mat-heuristic With Machine Learning Based Prediction for Software Defined Mobile MetroCore Networks[17]	Rodolfo -Alvizu	IEEE/OSA Journal of Optical Communications and Networking	An efficient mat-heuristic with ANN is considered for dynamic routing decisions in mobile networks to achieve energy efficiency. This approach improves speed for network dynamicity by 53% to 88% in comparison to static method. Machine learning approach is used to predict tidal traffic variations in a mobile network.	It does not implement reconfiguration system which could minimize the delay and avoid congestion due to route changes.
2017	Enhancing Mobile Network With Software-Defined-Networking and Cloud Computing[18]	Zizhong -Cao	IEEE/ACM TRANSACTIONS	This paper discusses flexible (policy aware) routing in 5th generation of mobile networks. A fast log competitive approximation algorithm is used for routing in SDMN(SDN and cloud is developed).	This algorithm considers only latency and bandwidth constraints with respect to time duals.
2016	Energy aware optimization of mobile metrocore network under predictable aggregated traffic patterns[19]	Rodolfo -Alvizu	IEEE ICC 2016 (Optical networks and systems)	In this paper, a real time data of a city in china is taken into consideration to study the spatiotemporal fluctuations of traffic at various cell and at the metro-core networks.	Here offline prediction based network optimization is done which provides over provisioned resources only.
2016	Energy Efficient Dynamic Optical Routing for Mobile	Rodolfo -Alvizu	IEEE- Lightwave Technology Journal	In this paper an online optimization mat-heuristic is proposed. This algorithm	Main drawback of this work is both offline

	Metro-Core - Networks Under Tidal Traffic Patterns[20]			reduces routing changes(to remove disruptions) and improves resource allocation accuracy(to increase savings of energy)	planning and reconfiguration time points calculation were performed one time for several days by using average value of tidal traffic pattern.
2015	Machine-Learning Based Routing Preplan for SoftwareDefinedNetworks[21]	Fengqing Chen	Lecture Notes in Computer book series	This paper proposes an efficient SDN routing pre design solution. <ul style="list-style-type: none"> • feature fetching • requirement gathering • route finding 	
2015	Considerations of Effective Tidal Traffic Dispatching in Software-Defined-Metro-IP over Optical-Networks[22]	Zhizhen -Zhong	OptoElectronics and Communications Conference, 2015	This paper focuses on both time and spatial domain of tidal traffic. It considers network blocking probability in simulation results. This algorithm of TIDAL model leaves us with the optimal routing and grooming technique for the IP traffic. This model reduces the network blocking probability. It focuses on global optimum by considering the concept of short light path.	This algorithm considers only two tidal traffic patterns i.e residential and business and uses dijkstra algorithm.

VI. CONCLUSION

In this paper various techniques of analysis of mobile traffic without SDMN and with SDMN are studied. In these algorithms there is a necessity to make new modifications which will outperform all these existing algorithms and will consider linear as well as non linear data traffic into consideration. Till now there is not a single algorithm which perform best in every situation either in a single cell or in whole region .Various works shows the combination of two or more models which results in a better forecasting accuracy.

REFERENCES

- [1] T. Cisco, Cisco Visual Networking Index: Global Mobile Data Traffic Forecast Update 2014–2019 White Paper, vol. 2011, no. 4. 2011.
- [2] T. Chen, V. T. T. Technical, and N. Nikaein, “Towards Software Defined 5G Radio Access Networks,” no. March 2016, pp. 1–7, 2018.
- [3] D. Karvounas, “5G on the Horizon,” no. sEptEmbEr, pp. 1–8, 2013.
- [4] Jie Yang, Weicheng Li, Yuanyuan Qiao and Zubair Md. Fadlullah, Nei Kato, “Characterizing and Modeling of Large-Scale Traffic in Mobile Network,” in 2015 IEEE Wireless Communications and Networking Conference (WCNC), LA USA, New Orleans, 2015, pp. 801-806.
- [5] Z. Liang and Y. Wakahara, “City traffic prediction based on real-time traffic information for intelligent transport systems,” in ITS Telecommunications (ITST), 2013 13th International Conference on IEEE, 2013, pp. 378–383.
- [6] Cisco Visual Networking Index, “Global Mobile Data Traffic Forecast Update 2014-2019 White Paper”,2014.
- [7] Jun Zhao, “Research on Prediction of Traffic Congestion State,” MATEC Web of Conferences, 2015,vol. 22.
- [8] Shiliang Sun, Changshui Zhang, and Guoqiang Yu. A bayesian network approach to traffic flow forecasting.Intelligent Transportation Systems, IEEE Transactions on, 7(1):124 –132, march 2006.

- [9] R. Chrobok, J. Wahle, and M. Schreckenberg. Traffic forecast using simulations of large scale networks. In *Intelligent Transportation Systems, 2001. Proceedings. 2001 IEEE*, pages 434–439, 2001.
- [10] Hussein Dia. An object-oriented neural network approach to short-term traffic forecasting. *European Journal of Operational Research*, 131(2):253–261, 2001.
- [11] Feng Jin and Shiliang Sun. Neural network multitask learning for traffic flow forecasting. In *Neural Networks, 2008. IJCNN 2008. (IEEE World Congress on Computational Intelligence). IEEE International Joint Conference on*, pages 1897–1901, June 2008.
- [12] Daniel B. Fambro Sangsoo Lee. Application of subset autoregressive integrated moving average model for short-term freeway traffic volume forecasting. *Transportation Research Record: Journal of the Transportation Research Board*, pages 179–188, 2007.
- [13] Goodwin, P. 2010. The Holt-Winters Approach to Exponential Smoothing: 50 Years Old and Going Strong. *Foresight* 19:30-33
- [14] S.C. Chang, R.S. Kim, S.J. Kim, and M.H. Ahn. Traffic-flow forecasting using a 3-stage model. In *Intelligent Vehicles Symposium, 2000. IV 2000. Proceedings of the IEEE*, pages 451–456, 2000.
- [15] M. Joshi and T. H. Hadi, “A Review of Network Traffic Analysis and Prediction Techniques,” p. 23, 2015.
- [16] Ali Yadavar Nikravesh Samuel A. Ajila Chung-Horng Lung, Wayne Ding, “Mobile Network Traffic Prediction Using MLP, MLPWD, and SVM,” in *2016 IEEE International Congress on Big Data*, 2016, pp. 402-409.
- [17] R. Alvizu, S. Troia, G. Maier, and A. Pattavina, “Matheuristic With Machine-Learning-Based Prediction for Software-Defined Mobile Metro-Core Networks,” *J. Opt. Commun. Netw.*, vol. 9, no. 9, p. D19, 2017.
- [18] Z. Cao, S. Member, S. S. Panwar, M. Kodialam, and T. V Lakshman, “Networking and Cloud Computing,” vol. 25, no. 3, pp. 1–14, 2017.
- [19] R. Alvizu, X. Zhao, G. Maier, Y. Xu, and A. Pattavina, “Energy aware optimization of mobile metro-core network under predictable aggregated traffic patterns,” *2016 IEEE Int. Conf. Commun. ICC 2016*, 2016.
- [20] R. Alvizu, X. Zhao, G. Maier, Y. Xu, and A. Pattavina, “Energy efficient dynamic optical routing for mobile metro-core networks under tidal traffic patterns,” *J. Light. Technol.*, vol. 35, no. 2, pp. 325–333, 2017.
- [21] I. Workshop, A. I. Multi, A. Intelligence, F. Chen, X. Zheng, C. Science, N. Computing, I. I. Processing, F. Online, D. Part, L. Notes, and C. Science, “Machine Learning Based Routing Pre plan for SDN,” pp. 1–17, 2018.
- [22] Z. Zhong, N. Hua, H. Liu, Y. Li, and X. Zheng, “Considerations of effective tidal traffic dispatching in software-defined metro IP over optical networks,” *2015 Opto-Electronics Commun. Conf. OECC 2015*, 2015.